

Project _____
 Item _____
 Quantity _____
 CSI Section 11400
 Approved _____
 Date _____

USP0100 CrystalCraft™

USP0100 CrystalCraft™ Ice Machine

Model - 60Hz

USP0100



Model USP0100
CrystalCraft
Ice Machine

Standard Features

- Up to 100 lbs (45.4 kgs) of daily square cube ice production.
- 38 lbs (17.2 kgs) or 868 cubes ice storage capacity.
- Heavy duty stainless steel cabinet resists corrosion.
- Square cube ice adds to the presentation of the drink and differentiates it from the competition

Standard Equipment

Ice Scoop, 6" Bin Legs, Standard Legs Adjustable from 4-1/2" to 6"

Warranty

3 years parts and labor.

Ice Machine Electric

- 115/60/1
115/60/1 ice machines are factory pre-wired with a 6' (180 cm) power cord and NEMA 5-15P plug configuration

Total ampacity:

Air-cooled: 10 amps

Maximum fuse size:

Air-cooled: 15 amps

HACR-type circuit breakers can be used in place of fuses

Specifications

Condenser Heat of Rejection (BTU per hour):

2350 Average
3637 peak

Compressor:

Nominal rating: 1/3 HP

Refrigerant:

R290

Operating Limits:

Ambient
Temperature Range:
50°-110°F (10°-43°C)

Water
Temperature Range:
40°-90°F (4°-32°C)

Water Pressure Ice Maker
Water In:
Min. 20 psi (137.9 kPa)
Max. 80 psi (551.6 kPa)

Ice Shape

The crystal clear square cube weighs 22.5g and is 1"x1"





USP0100 CrystalCraft™ Machine

USP0100

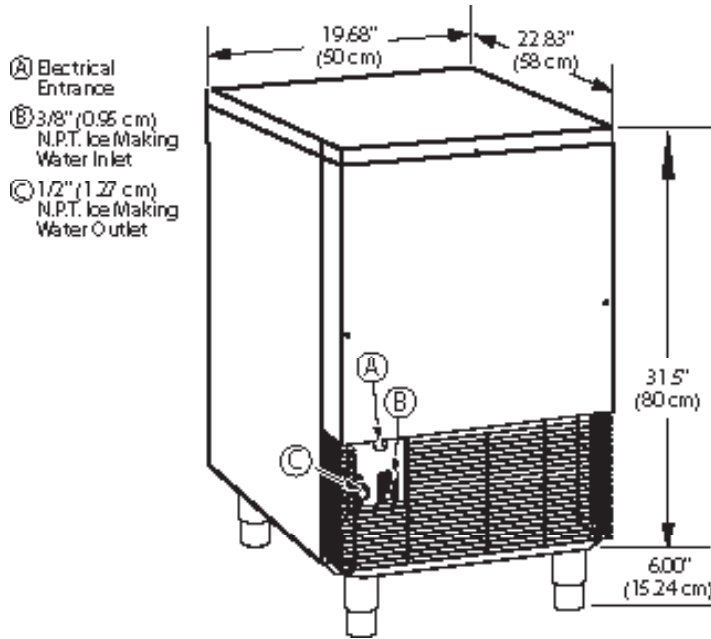

- (A) Electrical Entrance
- (B) 3/8" (0.95 cm) N.P.T. Ice Making Water Inlet
- (C) 1/2" (1.27 cm) N.P.T. Ice Making Water Outlet

Installation Note
 Minimum installation clearance:
 Sides: 2" (5.1 cm), back: 8" (20.3 cm), top: 2" (5.1 cm)

Space-Saving Designs



USP0100

Height	37.5" 95.25 cm
Width	19.68" 50 cm
Depth	22.83" 58 cm
Bin Storage	38 lbs. 17.2 kgs

Height includes adjustable bin legs 4.50" to 6.00", 11.43 cm to 15.24 cm set at 6.00" (15.24 cm).

Air Flow Overhead View

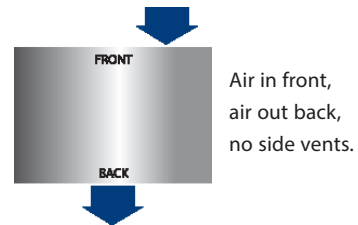

Air-cooled Ice Machine	Model	Ice Shape	Ice Production 24 Hours		Power kWh/100 lbs @ 90°Air/70°F	Potable Water Usage (100 lbs./45.4 kgs of Ice)	Bin Storage Capacity
			70°Air/50°F Water	90°Air/70°F Water			
	USP0100	Square	100 lbs.	85 lbs.	9.62	55 gal.	38 lbs.
			45.4 kgs	38.5 kgs			

Welbilt reserves the right to make changes to the design or specifications without prior notice.