



# BEVERAGE-AIR

Project: _____	AIA#
Item: _____	
Location: _____	SIS#
Approved: _____	

## UCFD UNDERCOUNTER FREEZER

UCFD48AHC Four Drawer Model  
Hydrocarbon Series

MODELS:  
UCFD48AHC-4

**3 Year Parts/Labor Warranty**  
**Additional 2 Year Compressor Warranty**

### CABINET CONSTRUCTION



UCFD48AHC-4

- Stainless steel front, sides, top and drawers, (*galvanized back & bottom*)
- Interior liner is made of corrosion resistant aluminum
- Full electronic control
- Interior thermometer is standard
- Durable sub-top insulated for added durability
- Magnetic gaskets attached to each drawer for positive seal
- Painted aluminum drawer handles
- 6" Casters, two (2) with brakes standard
- Stainless steel drawer frames supported on telescoping drawer slides
- Drawer slides include locking mechanism that prevents drawer from being inadvertently pulled off cabinet
- Upper and Lower pull out drawers accommodate 6" deep pans

### OPTIONS & ACCESSORIES

- Stainless steel back and grille
- Stainless steel interior
- 3" Casters or 6" legs
- Low profile casters
- Remote option

### REFRIGERATION SYSTEM

- Refrigeration system uses R290 refrigerant to comply with all environmental concerns
- Automatic, electric defrost
- Epoxy coated evaporator coil

UCFD48AHC-4 Undercounter Freezer: Food Prep Series



3779 Champion Blvd., Winston-Salem, NC 27105  
1-888-845-9800 Fax: 1-336-245-6453  
Beverage-Air.com sales@bevair.com



# BEVERAGE-AIR

MODEL	UCFD48AHC-4
<b>EXTERNAL DIMENSIONAL DATA</b>	
Width Overall	48"
Depth Overall with Handles & Bumper	31 7/8"
Height Overall with 6" Casters	34 5/8"
Number of Drawers	4
Depth with Drawers Open Extended	48"
Drawers Opening (in)	Upper 19 5/8" x 9 3/8" Lower 19 5/8" x 9 3/8"
<b>INTERNAL DIMENSIONAL DATA</b>	
NET Capacity (cubic ft.)	11.04
Internal Width Overall (in)	44"
Internal Depth Overall (in)	23 1/2"
Internal Depth Useable (in)	Upper 18 1/2" Lower 15 3/8"
Internal Height Front (in)	23"
Internal Height Rear (in)	16"
<b>ELECTRICAL DATA</b>	
Full Load Amperes 115/60/1	7.0
<b>REFRIGERATION DATA</b>	
Horsepower	1/2
Capacity (BTU/Hr)*	1865
<b>WEIGHT DATA</b>	
Gross Weight (Crated lbs)	306"
Height - Crated	36"
Width - Crated	51"
Depth - Crated	33"

## Undercounter Freezer Four Drawer Model Models: UCFD48AHC-4

### Model Views

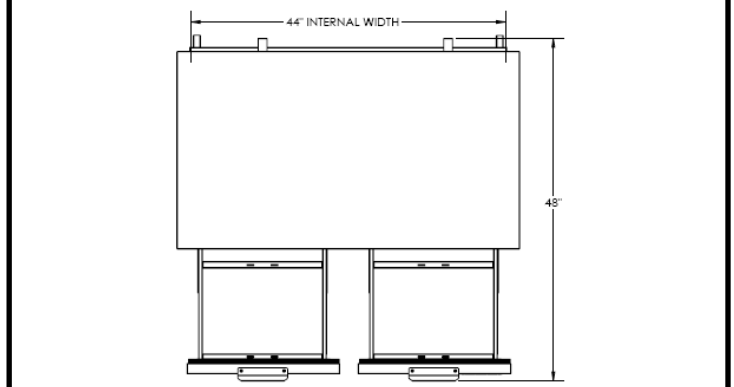

### Plan View

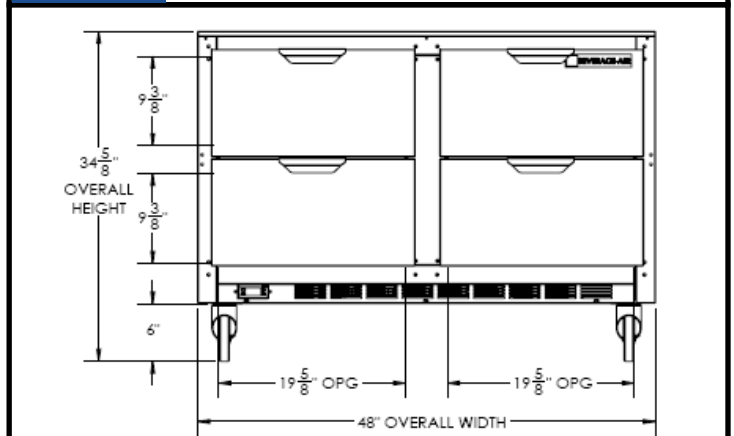

### Elevation View

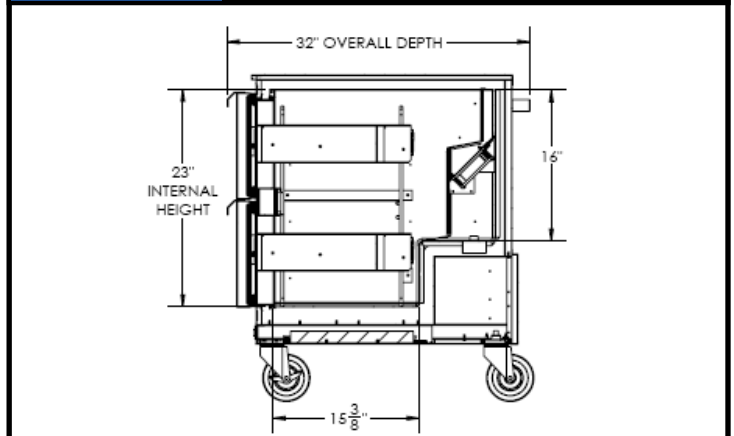

### Side View

### ELECTRICAL CONNECTION



115/60/1  
NEMA-5-15P

Units pre-wired at factory and include 8' long cord and plug set.



an Ali Group Company



The Spirit of Excellence

3779 Champion Blvd., Winston-Salem, NC 27105  
1-888-845-9800 Fax: 1-336-245-6453  
Beverage-Air.com sales@bevair.com