



BEVERAGE-AIR

Project: _____

AIA#

Item: _____

Location: _____

SIS#

Approved: _____

UNDERCOUNTER FREEZER

MODEL:

UCF20HC-25-15

UCF20HC-25-15 Shallow Glass Door Ice Cream Freezer

Hydrocarbon Series

UCF20HC Undercounter Ice Cream Freezer

3 Year Parts/Labor Warranty
Additional 4 Year Compressor Warranty

CABINET CONSTRUCTION



- Stainless steel front, sides, top, door, (*galvanized steel back & bottom*)
- Interior liner is made of corrosion resistant aluminum
- Full electronic control
- Undercounter feature a 1/2" thick sub-top
- Interior thermometer is standard
- Forced air design does not require unit to undergo manual defrost
- Self-closing door with 120° stay-open feature, on cartridge style hinges
- Easy door removal for service and cleaning
- Magnetic gasket attached to each door for positive seal
- Two epoxy-coated steel wire shelves standard
- Freezer temperatures is held at or -15°F to -10°F of below

OPTIONS & ACCESSORIES

- Stainless steel back and grille
- Stainless steel interior
- Right or left hinged door
- Door locks
- Wire shelf divider
- Additional shelves
- Stacking collar kit
- Wall mount accessory
- 3" or 6" Casters / 6" legs
- Low profile casters
- Remote option

REFRIGERATION SYSTEM

- Refrigeration system uses R290 refrigerant to comply with all environmental concerns
- Automatic, electric evaporator
- Epoxy coated evaporator coil



3779 Champion Blvd., Winston-Salem, NC 27105
1-888-845-9800 Fax: 1-336-245-6453
Beverage-Air.com Sales@bevair.com



BEVERAGE-AIR

MODEL	UCF20HC-25-15
EXTERNAL DIMENSIONAL DATA	
Width Overall	20"
Depth Overall	25"
Height Overall	25"
Number of Doors	1
Depth with Door Open 90°	42 1/8"
Door Opening (in)	15 1/2" x 18 1/8"
Shelf Area (sq. in)	186 1/2"
INTERNAL DIMENSIONAL DATA	
NET Capacity (cubic ft.)	2.25
Internal Width Overall (in)	20"
Internal Depth Overall (in)	8 1/4"
Internal Height Overall (in)	19 5/8"
Number of Shelves	2
ELECTRICAL DATA	
Full Load Amperes 115/60/1	3.7
REFRIGERATION DATA	
Horsepower	1/2
Capacity (BTU/Hr)*	1513
WEIGHT DATA	
Gross Weight (Crated lbs)	117 lbs
Height - Crated	35"
Width - Crated	23"
Depth - Crated	34"

Undercounter Ice Cream Freezer

Model: UCF20HC-25-15

Model Views

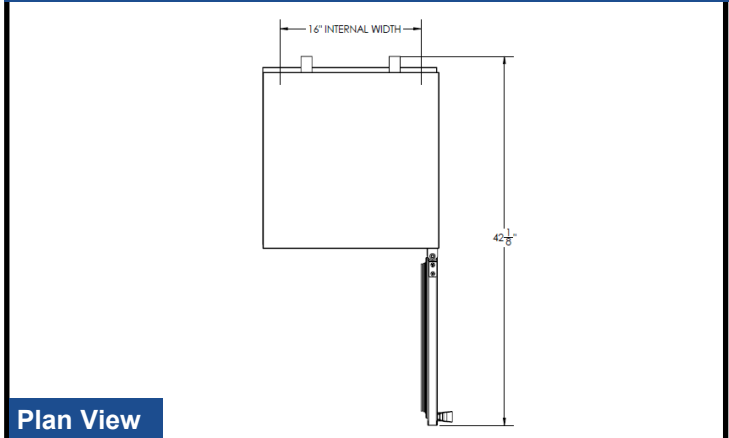

Plan View

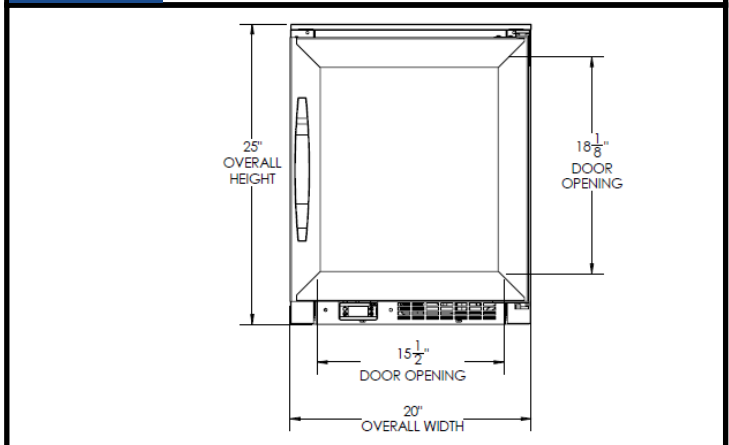

Elevation View

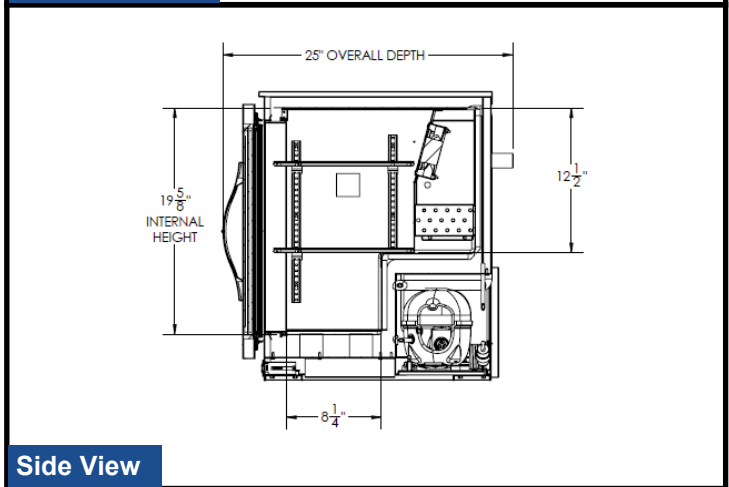

Side View

ELECTRICAL CONNECTION



115/60/1
NEMA-5-15P

Units pre-wired at factory and include 8' long cord and plug set.



an Ali Group Company



The Spirit of Excellence

3779 Champion Blvd., Winston-Salem, NC 27105
1-888-845-9800 Fax: 1-336-245-6453
Beverage-Air.com Sales@bevair.com