

REFRIGERATOR MANUFACTURER
Turbo air
 more durable, efficient, beautiful

4184 E. Conant St.
 Long Beach, CA 90808
 Tel. 310-900-1000
 Fax. 310-900-1077
www.turboairinc.com

Project:	
Model #:	
Item #:	
Available W/H:	Qty:
Approval:	
AIA #:	SIS #:
CSI Section 11400	

Sandwich & Cheese Display Cases

Open Display
Merchandisers

Patented Self-Cleaning Condenser



This product is equipped with a fine mesh filter to the front of the condenser to catch dust, and a rotating brush that moves up and down daily to remove excess buildup outward and away.

Model : TOS-40NN-D-W(B)



TOS-40NN-D-W

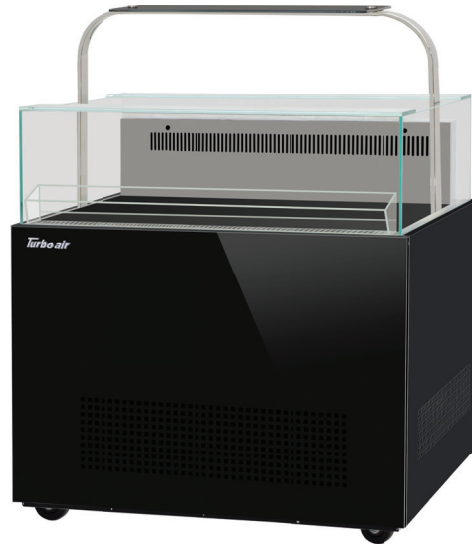

TOS-40NN-D-B

≡ FEATURES & BENEFITS ≡

■ Self-Cleaning Condenser

The accumulation of dust in the condenser can cause the failure or breakdown of refrigerators. Refrigerators run normally until they reach a certain level of accumulation. At some point, when they are over the limit, their performance drops quickly resulting in damage to, or disposal of the stored products inside. The Self-Cleaning Condenser device keeps the condenser clean and prevents system failure by automatically brushing daily.

■ Hydrocarbon refrigerants (R-290)

With innovative and eco-friendly technology, Turbo Air brings you hydrocarbon refrigerators designed to meet DOE's Energy Conservation Standards in 2017 and to use EPA's SNAP Program approved HC refrigerants. Hydrocarbon refrigerants do not deplete the ozone layer and have very low contribution to global warming (ODP-0, GWP-3).

■ Exterior and bottom glass shelf is white (black) with a mirror finish

■ Top shelf equipped

Top shelf is white (black) glass and frame is stainless steel, both with a mirror finish.

■ High-density polyurethane insulation

The entire cabinet structure is foamed-in-place using high density, CFC free polyurethane insulation.

■ Digital temperature controller

■ Single pane glass is tempered for safety

■ Stainless steel airflow grille

■ Self-contained system, no plumbing required

■ Factory-installed LED lamp option available

NATURAL
Refrigerant

ETL
Intertek

ETL
Intertek

2 YEAR
WARRANTY

Compressor
5 YEAR
WARRANTY
(U.S.A. only)

Model	Load Line CU./FT.	HP	AMPS	Crated Weight (lbs.)	L x D x H* (inches)
TOS-40NN-D-W(B)	1.83	1/3	8	572	40 1/4 x 35 3/8 x 40

Sandwich & Cheese Display Cases

Open Display Merchandisers

Model : TOS-40NN-D-W(B)

ELECTRICAL DATA	
Voltage	115/60/1
Plug Type	 NEMA 5-15P
Full Load Amperes	8
Compressor HP	1/3
Cord Length (ft.)	8 1/4
Refrigerant	R-290
DIMENSIONAL DATA	
Load Line Net Capacity (cu. ft.)	1.83
Ext. Length Overall (in.)	40 1/4 (1022mm)
Ext. Depth Overall (in.)	35 3/8 (900mm)
Ext. Height Overall (in.)*	40 (1017mm)
Int. Length Overall (in.)	35 3/8 (900mm)
Int. Depth Overall (in.)	25 1/4 (641mm)
Int. Height Overall (in.)	6 1/2 (164mm)
Int. Height Load limit (in.)	3 1/2 (90mm)
Top Shelf Size (L x D)(in.)	27 1/2 x 9 7/8
Net Weight (lbs.)	385
Gross Weight (lbs.)	572

Design and specifications subject to change without notice.

Actual shipping weight may differ due to extra packing materials for product protection.

* Height does not include 2-1/4" for caster height.

■ **WARRANTY : 2 Year Parts and Labor Warranty**
Additional 3 Year Warranty on Compressor

■ STANDARD FEATURES

- White and black color come standard
- 3" dia. swivel casters with locks on the rear set

**Lead time applies. Please contact your sales representative for more details to order.

■ Recommended operating conditions

TOS models are designed to operate in an environment where temperature & humidity do not exceed 75°F and 55% respectively. Keep the cycle air duct area clear of objects for optimal cooling.

PLAN VIEW

(unit : inch)

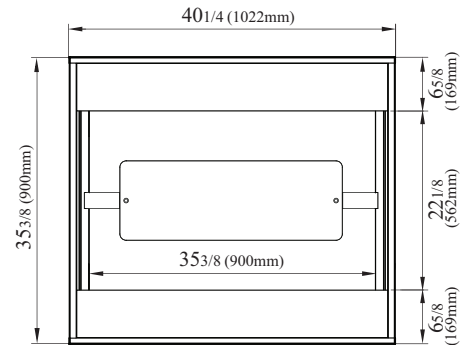

TOP VIEW

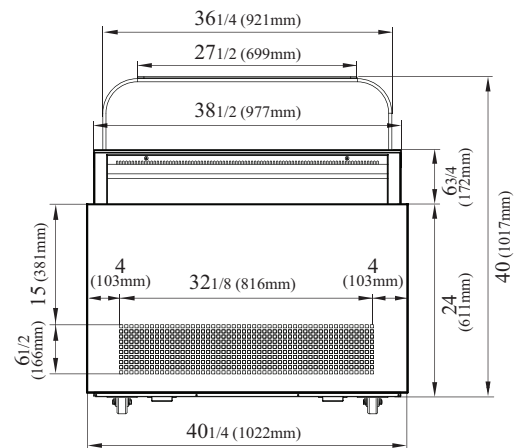

FRONT VIEW

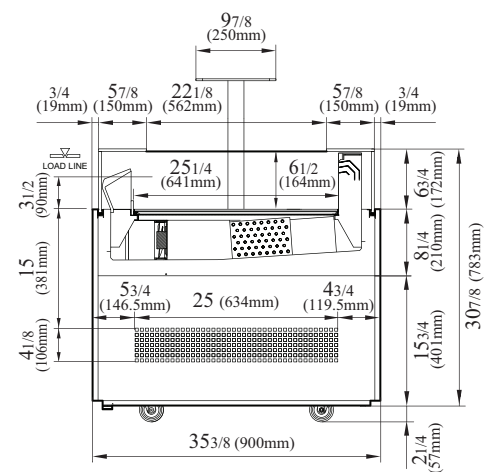

SIDE VIEW

Ver.20210218



■ Turbo Air : 800-627-0032 ■ GK : 800-500-3519
 ■ Warranty : 800-381-7770 ■ AC : 888-900-1002



Continued product development may necessitate specification changes without notice.