

Project:	Quantity:
Model #:	Approval:

SR-SM36 36" Gas Salamander Infra-Red Broiler



DESCRIPTION

This 36" Gas Salamander Infra-Red Broiler comes with 1 single burner and delivers 35,000 BTU of total heating power. It provides 3-level broiling positions ideal for beef, chicken, and fish products. Powerful infrared burner ensures even heat distribution and customer satisfaction.

STANDARD FEATURES

- Stainless Steel front and Sides
- 35,000 BTU Infrared burner
- Manual gas control from 300°F to 1000°F
- Standing pilot ignition system
- Sides and back are galvanized steel
- Full width broiler pan
- 3/4" rear gas connection with regulator
- 3 Position Adjustable spring balanced rack
- Ball grip handle on adjustable rack for ease and comfort
- LP gas conversion kit included
- Ready to mount over any Core Pro 36 60 inch range
- 4" adjustable height, non-skid SS Legs

- CSA
- cCSAus
- CSA Sanitation



USR BRANDS is a US supplier of premium quality commercial cooking, refrigeration and food preparation equipment. Our aim is simple. Produce industry-leading commercial restaurant equipment at reasonable prices, and back it all up with an easy to understand, no nonsense warranty that people can count on.

Project:	Quantity:
Model #:	Approval:

TECHNICAL DATA

DIMENSIONS

Exterior Dimensions	36" L x 25" D x 18" H
Packaging Dimensions	39" L x 27" D x 24" H
Cooking Area Dimensions	27.5" L x 12.6" D
Unit Weight	128 lb.
Shipping Weight	186 lb.

COOKING

Number of Oven Rack	1
Total BTU	35,000
Control Type	Manual
Gas Inlet Size	3/4"
Gas Type	Natural Gas

CONSTRUCTION

Exterior Material	Stainless Steel
Frame Structure	Welded
Number of leg	4

TECHNICAL DRAWING

FRONT VIEW

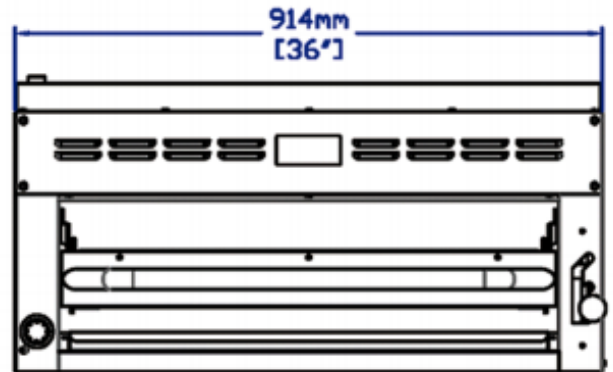

SIDE VIEW

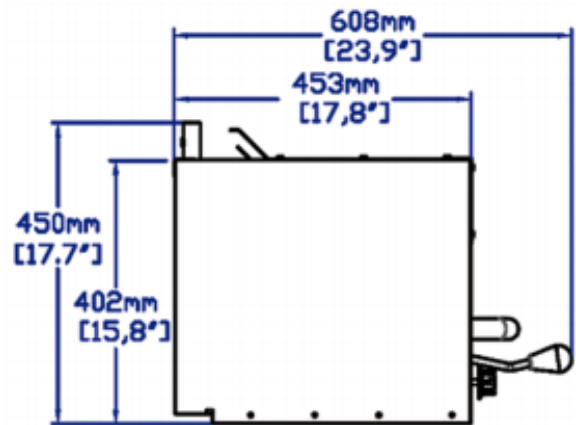

TOP VIEW

