



BEVERAGE-AIR

Project: _____	AIA#
Item: _____	SIS#
Location: _____	
Approved: _____	

SPE FOOD PREPERATION TABLES

SPE27HC Elite Series Sandwich Prep

Hydrocarbon Series

MODELS:
SPE27HC-12M



SPE27HC-12M

3 Year Parts/Labor Warranty
Additional 2 Year Compressor Warranty

CABINET CONSTRUCTION

- Stainless steel front, sides, top, door, and grille (galvanized back & bottom)
- Interior liner is made of corrosion resistant aluminum
- Full electronic control
- Removable hoods and insulated lid assemblies are made of matching stainless steel
- Airflow assures that product in open containers is kept below 41°F and above freezing
- Self-closing doors with 120° Stay-open feature, on cartridge style hinges
- Easy door removal for service and cleaning
- Field-reversible doors with snap-in door gaskets
- Painted aluminum door handle
- 6" Casters, 2 with brakes standard
- 10" Wide cutting board constructed of white polyethylene plastic
- Cutting board removable for cleaning
- Two (2) epoxy-coated steel wire shelves standard
- Nine (9) 1/6 4" deep pans constructed of polycarbonate plastic
- Three (3) 1/9 4" deep pans constructed of polycarbonate plastic
- Enhanced airflow maintains temperature between 36° to 38°F

REFRIGERATION SYSTEM

- Refrigeration system uses R290 refrigerant to comply with all environmental concerns
- Recirculated, forced air from evaporator is moved under pans, which are recessed 2" from top of cabinet
- Automatic condensate evaporator is provided to eliminate the need of floor drains

OPTIONS & ACCESSORIES

- Stainless steel back option available
- Stainless steel interior option available
- Remote option
- Overshelves (single or double)
- Drawers models
- Side and front crumb catcher
- 6" legs or 3" casters available
- Low profile casters
- Richlite & composite cutting board
- Night cover
- Dressing holder
- Shelf dividers

SPE27HC Elite Series Sandwich Prep: Mega Top Series



3779 Champion Blvd., Winston-Salem, NC 27105
1-888-845-9800 Fax: 1-336-245-6453
Beverage-Air.com sales@bevair.com



BEVERAGE-AIR

Food Preparation Table - Mega Top

Models: SPE27HC-12M

MODEL	SPE27HC-12M
EXTERNAL DIMENSIONAL DATA	
Width Overall	27"
Depth Overall with Bumper	38 3/8"
Height Overall with 6" Casters	49 1/8"
Number of Doors	1
Depth with Door Open 90 ° Extended	55 3/8"
Solid Door Opening (in)	22 5/8" x 21 5/8"
Depth, Cutting Board	10"
Shelf Area (sq. in.)	Upper 389 3/8" Lower 322 5/8 "
INTERNAL DIMENSIONAL DATA	
NET Capacity (cubic ft.)	4.8
Internal Width Overall (in)	23"
Internal Depth Overall (in)	23 1/2"
Internal Depth Useable (in)	Upper 18 1/2" Lower 15 1/2"
Internal Height Overall (in)	23"
Internal Height Useable (in)	17 5/8"
Number of Shelves	2
Number of Pans	(9) 1/6 size & (3) 1/9 size
ELECTRICAL DATA	
Full Load Amperes 115/60/1	2
REFRIGERATION DATA	
Horsepower	1/6
Capacity (BTU/Hr)*	1140
WEIGHT DATA	
Gross Weight (Crated lbs)	220 lbs
Height - Crated	48"
Width - Crated	30"
Depth - Crated	37"

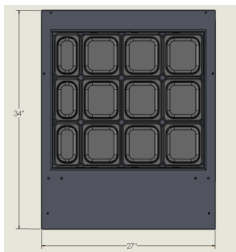

Model Views

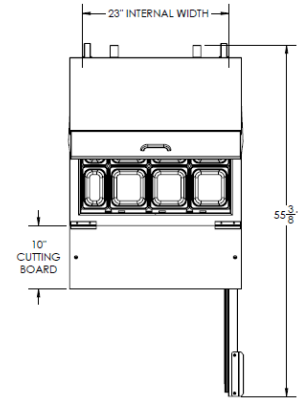

Plan View

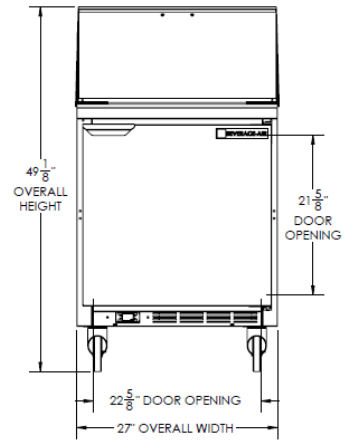

Elevation View

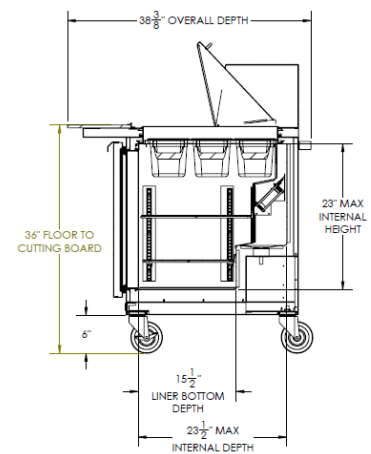

Side View

ELECTRICAL CONNECTION



115/60/1
NEMA-5-15P

Units pre-wired at factory and include 8' long cord and plug set.



an Ali Group Company



The Spirit of Excellence

3779 Champion Blvd., Winston-Salem, NC 27105
1-888-845-9800 Fax: 1-336-245-6453
Beverage-Air.com sales@bevair.com