

Project :	
Model # :	
Item # :	Qty :
Available W/H :	
Approval :	

Sneeze Guard



Model : SNZ-



SNZ-60

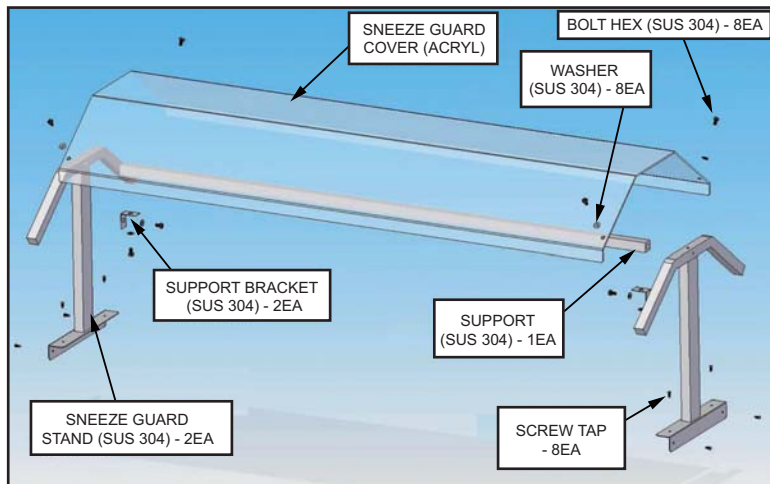

FEATURES & BENEFITS

- Double sided sneeze guard keeps the food safe and protects the food area from germs and foreign objects
- A transparent acryl cover is durable and 304 stainless steel two side stands are easy to clean and anti-corrosive
- The package includes support brackets and mounting hardware (Except tools)

PLAN VIEW

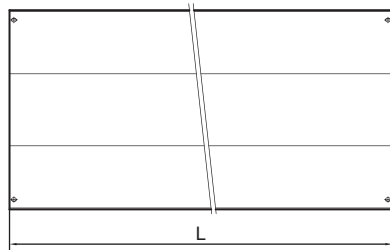

COVER PLAN VIEW

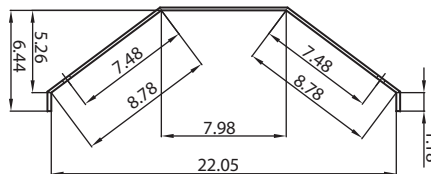

COVER SIDE VIEW

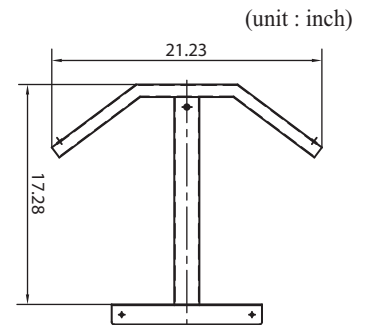

STAND SIDE VIEW

(unit : inch)

Model	L	D	H	Net Weight
SNZ-36	35	22 ¹ / ₈	17 ¹ / ₄	11
SNZ-48	46 ⁷ / ₈	22 ¹ / ₈	17 ¹ / ₄	13.5
SNZ-60	58 ⁵ / ₈	22 ¹ / ₈	17 ¹ / ₄	16
SNZ-72	70 ¹ / ₂	22 ¹ / ₈	17 ¹ / ₄	18.4