

Project:	Quantity:
Model #:	Approval:

For Commercial Use Only

PHLM10B-T 10-Quart Gear Driven Commercial Planetary Stand Mixer with Timer



FEATURES

- Planetary mixer
- Aluminum construction
- Heavy-duty use
- With (0-30) minute timer function
- Wire bowl safety guard
- 3-speed control
- Hook, paddle, whip included
- Push-button controls
- Countertop and floor usage

The Prepline commercial electric planetary mixer is designed for heavy duty use in commercial kitchen. This planetary mixer will come through, however hard the job appears to be. Unique planetary mixing action ensures that all your ingredients are mixed completely so you can prepare your recipes with ease. Whether you're looking to mix dough, cake ingredients, or cookie batters - the Prepline commercial planetary stand mixer makes the job super easy and better performance.

- cETLus Listed
 - ETL Sanitation Listed
- Conforms to UL & NSF Standards



USR Brands is a US supplier of premium quality commercial cooking, refrigeration and food preparation equipment. Our aim is simple. Produce industry-leading commercial restaurant equipment at reasonable prices, and back it all up with an easy to understand, no nonsense warranty that people can count on.

For Commercial Use Only

TECHNICAL DATA

DIMENSIONS

Overall Dimensions	20"L x 18.7"D x 28"H
Packaging Dimensions	22"L x 20 x 30"H
Capacity	10 qt.
Unit Weight	79 lb.
Shipping Weight	106 lb.

ELECTRICAL

Voltage	110
Hertz	60
Phase	1
Wattage	550 / 750
Plug Type	NEMA 5-15P
Power Cord Length	72"

MIXING

Mixer Type	Planetary
Mixing Heads	1
Transmission Type	Gear Driven
Number of Gear Speed	3
Horsepower	3/4
Speed (RPM)	113 - 400
Control Type	Push Button
Bowl Guard Type	Wire
Bowl Lift Control	Manual
Dry Dough Capacity	6 lbs.
Dough Capacity	9 lbs.

CONSTRUCTION

Exterior Material	Aluminum
Accessories Included	Stainless Steel Mixing Bowl Stainless Steel Wire Whisk Aluminum Dough Hook Aluminum Flat Beater
Feet	Rubber

DIAGRAM

MODEL: PHLM10B-T

MFR MODEL:



FRONT VIEW

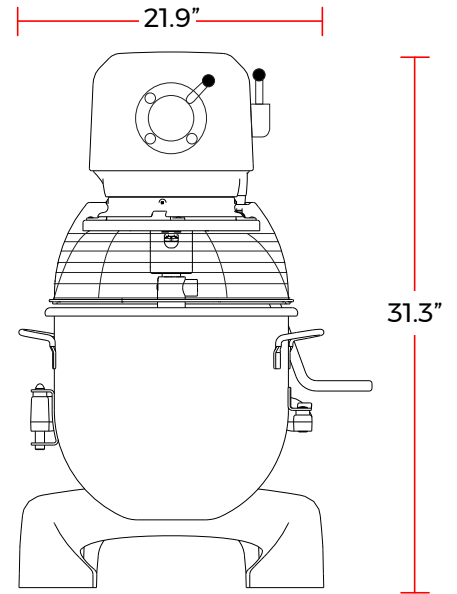

SIDE VIEW

