

Project:	Quantity:
Model #:	Approval:

For Commercial Use Only

MC22 #22 HUB Head Size 1 HP 450 lbs. Meat Grinder



FEATURES

- Heavy-duty high torque motor
- Manual reset motor overload protection
- Gear-driven transmission
- Long lasting grease-lubricated gear box
- Forward and reverse switch
- Top-mounted handle with tray support
- Non-slip rubber feet
- 1/4" (6mm), and 5/16" (8mm) extruder plate
- Plastic food pusher
- #22 HUB head size attachment
- 450 lbs/hour production

This Prepline MC-series meat grinder is an ideal piece of equipment for small butcher shops, delis, and restaurants. This professional meat chopper facilitates prompt and efficient breakdown of sausage, beef, wild game, and other meats to save time and labor in your establishment. Maximize your meat processing capabilities and get more value for money with a Prepline industrial meat grinder.

• CE Certified



USR Brands is a US supplier of premium quality commercial cooking, refrigeration and food preparation equipment. Our aim is simple. Produce industry-leading commercial restaurant equipment at reasonable prices, and back it all up with an easy to understand, no nonsense warranty that people can count on.

TECHNICAL DATA

DIMENSIONS

Overall Dimensions	9.3"L x 18.6"D x 21"H
Packaging Dimensions	15"L x 22"W x 23"H
Unit Weight	76 lb.
Shipping Weight	84 lb.

ELECTRICAL

Voltage	115
Hertz	60
Phase	1
Watts	1100
Amps	16
Plug Type	NEMA 5-15P
Power Cord Length	72"

GRINDING

HUB Head Size	#22
Production Capacity	450 lbs./hr
Extruder Disc/Plate	1/4" (6mm), 5/16" (8mm)
Horsepower	1.5
RPM	170

CONSTRUCTION

Exterior Material	Stainless Steel
Reverse Switch	Yes
Power Button Type	Push
Standard Accessories	Knife Stainless Steel Product Tray 1/4" and 5/16" Plate Plastic Food Pusher

DIAGRAM

MODEL: MC22



NEMA 5-15P

FRONT VIEW

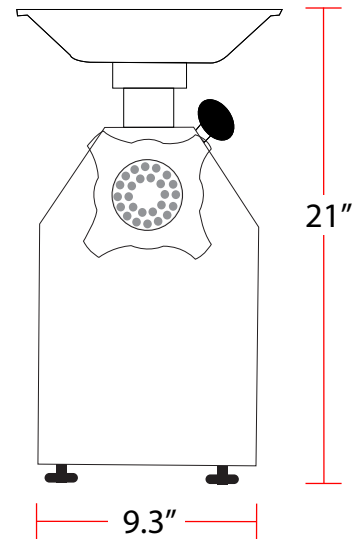

SIDE VIEW

