

QuietQube[®] iF1400C-A Remote Ice Cube Machine

Air-Cooled Ice Cube Machine with Patented CVD Technology[®]

Models

- IDF1400C IYF1400C



IDF1400C Ice Cube Machine - 115V

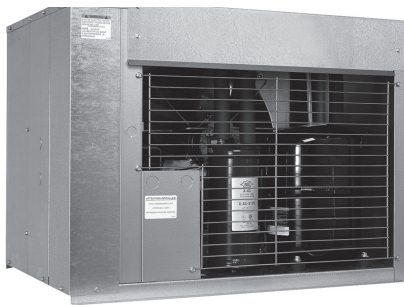

CVDF1400 Condensing Unit



IDF1400C
Ice Machine
on a D-970 Bin

Two IDF1400C
Ice Machines
on a F-1650 Bin

*Ice machine and bin sold separately

Standard Features

QuietQube Series Remote System consists of a remote condensing unit, interconnecting refrigerant lines, ice machine head section along with an ice storage bin, countertop dispenser, or floor dispenser. All ordered separately. QuietQube ice machine with CVD condensing unit is designed as a Manitowoc system and cannot be used with any other ice machine or remote condenser brand.

- **Space-Saving Design** - Up to 1,410 lbs. (640 kgs.) daily ice production and only 30" (76.20 cm) wide.
- **Quiet Operation** - eliminates most noise from the refrigeration system. Promotes a relaxing atmosphere.
- **easyTouch[®] Display** - New icon based touch screen takes the guess work out of owning and operating an ice machine.
- **Programmable Ice Production** - Now its super easy to program your ice machine to be off at certain times of the day to save money with fluctuating electrical rates. Also programmable by daily ice production volume and night time program.
- **Easy to Clean Foodzone** - Hung door for easy access. Removable water-trough, distribution tube, splash guard, water probe and water pump for fast and efficient cleaning. Selected components are made with AlphaSan[®] antimicrobial.
- **Intelligent Diagnostics** - Provides 24 hour preventative maintenance and diagnostic feedback for trouble free operation.
- **Acoustical Ice Sensing Probe** - Unique patented technology allows for reliable operation in challenging water conditions and environments
- **DuraTech[®] Exterior** - Provides superior corrosion resistant above stainless steel. Innovative clear-coat resists fingerprints and dirt making it easier to keep clean.
- **Available LumInIce[®] II Virus and Bacteria Inhibitor** - Controls viruses, bacteria, mold and yeast within the food zone to keep the machine clean longer. A new sanitation icon lets you know the operational status.
- **Active Sense** - Insures consistent ice harvest in all environmental conditions. This software solution works in conjunction with the acoustical ice sensing probe improving reliability and performance

COMMERCIAL WARRANTY		
ICE MAKER	EVAPORATOR	COMPRESSOR
3	5	5
YEAR	YEAR	YEAR PARTS
PARTS AND LABOR		3 YEAR LABOR

Ice Shape

Half Dice
 $\frac{3}{8}'' \times 1\frac{1}{8}'' \times \frac{7}{8}''$
 (.95 x 2.86 x 2.22 cm)

Dice
 $\frac{7}{8}'' \times \frac{7}{8}'' \times \frac{7}{8}''$
 (2.22 x 2.22 x 2.22 cm)



QuietQube[®] iF1400C Remote Ice Cube Machine



QuietQube® iF1400C-A Remote Ice Cube Machine

**iF1400C-A
Ice Machine**

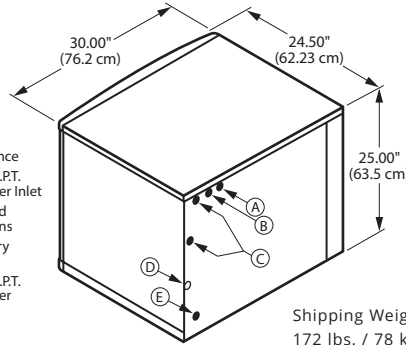

- Ⓐ Electrical Entrance
- Ⓑ 3/8" (0,95 cm) F.P.T. Ice Making Water Inlet
- Ⓒ Suction & Liquid Line Connections
- Ⓓ AuCS® Accessory Knockout
- Ⓔ 1/2" (1,27 cm) F.P.T. Ice Making Water Drain

Clearances required:
2" top, 8" sides, 5" back.

More space may be required for servicing

Shipping Weight:
172 lbs. / 78 kgs.

Ice Machine Electric Specifications

115/60/1 standard.

Total Amps: 1.1

Max. fuse size: 15 amps

HACR-type circuit breakers can be used in place of fuses.

Operating Limits:

Ambient Temperature Range: 40° to 110°F (4.4° to 43.4°C)

Water Temperature Range: 40° to 90°F (4.4° to 32.2°C)

Water Pressure Ice Maker Water In:

Min. 20 psi (137.9 kPa)

Max. 80 psi (551.1 kPa)

Remote Air-Cooled Ice Machine

Model	Ice Shape	Ice Production 24 Hours		Power kWh/ 100 lbs. @90°Air/70°F*	Potable Water Usage/ 100 lbs. 45.4 kg of Ice*
		70°Air/ 50°F Water	90°Air/ 70°F Water		
IDF1400C	dice	1,350 lbs.	1,120 lbs.	4.79	18 gal.
		612 kgs.	508 kgs.		
IYF1400C	half-dice	1,425 lbs.	1,230 lbs.	4.40	18 gal.
		646 kgs.	558 kgs.		

Ice machine for use with ice dispenser, CVD condensing unit and dispenser adapter. All ordered separately. kWh per 100 lbs. is total power of ice machine and condensing unit. Ice machine is 1 ph only. Condensing unit is 1 ph or 3 ph.



*Ratings Certified in Accordance with AHRI Standard 810.

Interconnecting Tubing

Model	Line Length		Weight	
	ft.	m	lbs.	kg
RC-20	20	6	14	6
RC-30	30	9	20	9
RC-50	50	15	31	14

Accessories

**LuminIce® II
Virus and Bacteria
Inhibitor**

controls viruses and bacteria inside the ice machine



**External
Scoop holder**

protect the ice scoop with the NSF approved versatile scoop holder.



**Arctic Pure®
Water Filters**

reduces sediment and chlorine odors for better tasting ice.



iAuCS®

schedules and performs routine ice machine cleaning automatically.



**CVDF1400 Remote
Condensing Unit**

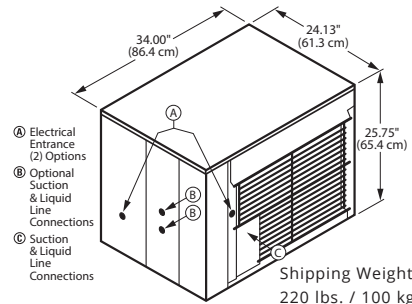

- Ⓐ Electrical Entrance (2) Options
- Ⓑ Optional Suction & Liquid Line Connections
- Ⓒ Suction & Liquid Line Connections

Shipping Weight:
220 lbs. / 100 kgs.

208-230/60/1 standard. 208-230/60/3 HACR-type circuit breakers can be used in place of fuses.

Note: QuietQube ice machine power supply is wired independent of CVD condensing unit.

Min. circuit ampacity:

20 1ph 15 3ph

Max. fuse size:

20 amps 1ph 15 amps 3ph

HACR-type circuit breakers can be used in place of fuses.

BTU Per Hour:

17,800 (average) 20,500 (peak)

Compressor:

Nominal rating: 1.75 HP

Operating Limits:

Ambient Temperature Range:

-20° to 120°F (-29° to 48.9°C)

Installation Information and Dimensions:

Maximum Line Length

—100' (30.5 m).*

Maximum Vertical Rise*

—35' (10.7 m) above ice machine.

Maximum Vertical Drop

—15' (4.5 m) below ice machine.

*A rise over 20' (6 m) requires S-Trap Kit K-00166 - ordered separately.

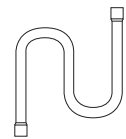

Welbilt reserves the right to make changes to the design or specifications without prior notice.