



iAuCS® Automatic Cleaning System

iAuCS® Automatic Cleaning System

Model

- iAuCS (for all Indigo NXT models except IB models) iBAuCS (for Indigo NXT IB models)



iAuCS for External Mounting

Standard Features

iAuCS

- Exterior finish is stainless steel.
- Flexible design allows unit to be mounted on bin or wall.
- Only 12" (30.48 cm) wide, 3.43" (8.7 cm) deep, 12.12" (30.78 cm) high.

Warranty

- 3-year warranty covering all parts and labor from the date of original installation.

An efficient, dependable, and affordable accessory that schedules and performs routine ice machine cleaning automatically.

The innovative iAuCS accessory virtually eliminates the need to have a service technician perform manual cleaning procedures on the water distribution system of your Manitowoc ice machine.

It is a known fact that regularly scheduled preventative maintenance (cleaning) reduces the total operating cost of any ice machine. With iAuCS, you simply select the monthly cleaning frequency through the Indigo NXT easyTouch display (0.5, 1, 2, 3, 4, 5, or 6 months) and iAuCS does the rest...automatically. The iAuCS is also affordable, as the entire system costs less than the expense of 3 manual cleanings. The iAuCS is designed for use with Manitowoc Indigo NXT Series ice machines.

Cleaning or Sanitizing:

- The iAuCS accessory can dispense either cleaner or sanitizer. It can not dispense both at the same time. Refer to the Installation Use and Care Manual supplied with the iAuCS accessory to determine the type of solution needed and proper procedure for changing solutions. Use only Manitowoc ice machine cleaner or sanitizer.
- Cleaner is used to remove and control build up of lime scale or other mineral deposits.
- Sanitizer is used to control algae (slime) and other air borne bacteria (yeast).

Electric

iAuCS

- 115/60/1 or 208-230/60/1 (50Hz is not available)
- Electricity drawn directly from the ice machine.
- Amp Rating: 0.1

iBAuCS

- 115/60/1 or 208-230/60/1 (50Hz is not available)
- Factory pre-wired with an 11' (335 cm) power cord and NEMA 5-15P plug.
- Amp Rating: 0.1

Replenishment

- iAuCS cleaning or sanitizing fluid is provided in either 16 oz. replacement bottles or 1 gallon containers for refilling.
- The iAuCS ships with an empty 16 oz bottle for filling either cleaner or sanitizer.



COMPANY WITH
QUALITY SYSTEM



iAuCS[®] Automatic Cleaning System

iAuCS / iBAuCS
(External Mounting)

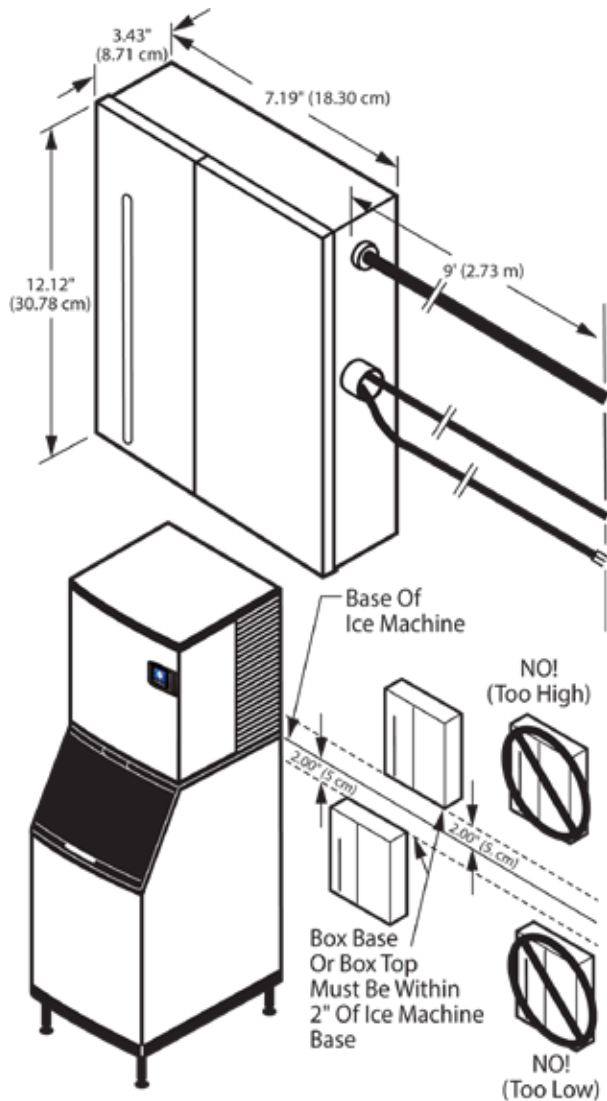

NOTE: Box must also mount within reach of 9 foot (274 cm) tubing and low voltage modular wire.



Compatibility: The iAuCS model is for use with all Indigo NXT Cubers from iF0300 to iT1900, Indigo NXT QuiteQubes models iF0600C to iF2100C. iBAuCS is for use with all Indigo NXT IB models, IBF0620C, IBF0820C and IBT1020C.

Installation: The iAuCS is mounted on the wall near the ice machine or on the bin with the included bracket and hardware. iAuCS line voltage is obtained from the ice machine. iBAuCS line voltage requires external supply (unit comes pre-wired with 11' cord and NEMA 15-5P plug).

Setting Run Frequency: The frequency of cleanings can be set through the menus of the Indigo NXT easyTouch display.

Automatic Operation: Automatic cleaning initiated by the iAuCS system takes about 30 minutes depending on the size of the machine. The water in the trough is dumped and refilled at the start of the cycle. The cleaner or sanitizer is dispensed from the iAuCS accessory and the water pump performs a wash cycle followed by a series of rinse cycles. Ice making automatically resumes when the iAuCS cycle is complete.

Welbilt reserves the right to make changes to the design or specifications without prior notice.