

KT-0300 Ice Kube Machine

KT-0300 ICE KUBE MACHINE

Models

KDT-0300A KYT-0300A



Koolaire KT-0300
Ice Kube Machine on K400 Bin

Koolaire by Manitowoc ice machines are designed, developed and tested by Manitowoc engineers to provide great ice production, energy efficiency and reliable service at an affordable price.

Performance/Features/Benefits

- Produces up to 330 lbs (150 kg) of ice per day**
- Performance certified by the Air Conditioning, Heating and Refrigeration Institute (AHRI)
- Energy Efficient models - visit EnergyStar.gov to view all Energy Star qualifying models
- Highly efficient electro-less nickel plated copper evaporators made in Manitowoc WI, USA
- Simple operation - only one control, three positions ON/OFF/CLEAN
- High-Tech exterior with smudge and fingerprint resistant stainless-like finish
- Better for the environment. Uses R410A refrigerant which lowers global warming potential by 48%
- Backed by the industry's best Manitowoc distribution network and service agents

Built for Easy Sanitation

- Easy access front facing evaporator
- One-touch remedial cleaning; requires minimal interaction; just add chemical and let the machine do the rest. No ice removal from bin needed. (Use Manitowoc De-scaler and Sanitizer only)
- For detail cleaning; all food zone components removable by hand (no tools required). Fast and easy
- All white plastic interior, no exposed tubes or wires, smooth rounded corners for fast easy wipe downs
- The food zone is sealed from above and on the back of the door panel with commercial grade rubber gaskets
- Alpha San anti-microbial agent molded in selected components
- Additional sanitation protection available with CleanAir™ packs to control the growth of bacteria, fungi and slime inside the food zone

**based on 70F air / 50F water

Ice Machine Electric

115/60/1 standard

Minimum circuit ampacity:

Air-cooled: 9.4

Maximum fuse size:

Air Cooled: 20 Amps

Specifications Operating Limits:

BTU Per Hour:
4,600 (average),
and 5,450 (peak)

Refrigerant:

R410A CFC - Free
Lowers global warming
by 48%

- Ambient Temperature Range: 40° to 110° F (4.4° to 43.3° C)
Water Temperature Range: 40° to 90° F (4.4° to 32.2° C)
- Water Pressure Ice Maker Water In:
Min. 20 psi (137.9 kPa)
Max. 80 psi (551.1 kPa)

Ice Shape



HALF KUBE
3/8" x 1 1/8" x 7/8"
(.95 x 2.86 x 2.22 cm)

❄️ = 100%



KUBE
7/8" x 7/8" x 7/8"
(2.22 x 2.22 x 2.22 cm)

❄️ = 100%



KT0300 on K-400 Storage Bin

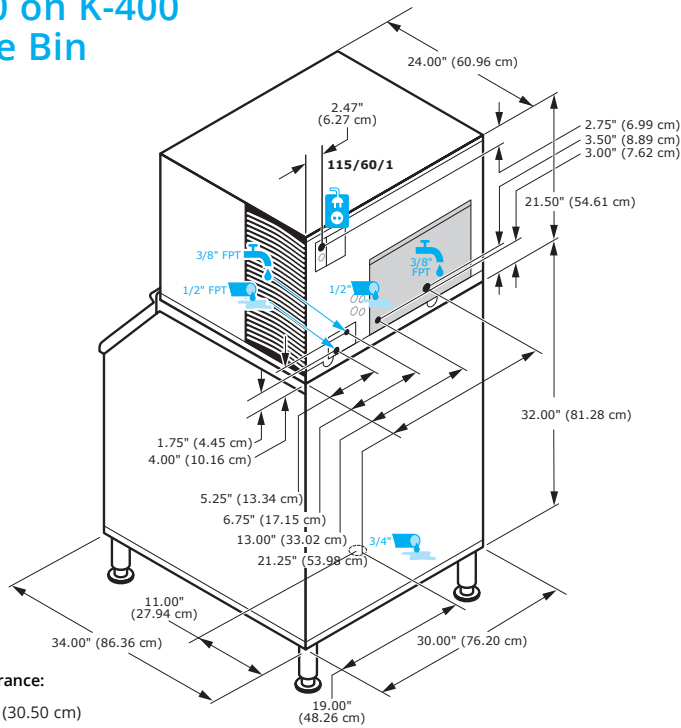

Required Clearance:
Top/Sides: 12" (30.50 cm)
Back: 5" (12.7 cm)

Space-Saving Design



	KT0300 K-400
Height	59.50" 151.13 cm
Width	30.00" 76.2 cm
Depth	34.00" 86.30 cm
Bin Storage	365 lbs. 165.7 kgs.

Measurements with bin legs at 6.00" (15.24cm). Adjustable bin legs 6.00" to 8.00" (15.24cm to 20.32cm). Bin capacity is based on 90% of the volume x 33 lbs/ft³ average density of ice.

Specifications

	Model	Ice Shape	Ice Production 24 Hours		Power Usage kWh/100 lbs. @90°Air/70°F 1 Ph	Potable Water Usage/100 lbs. of Ice 45.4 kgs. of Ice
			70°/ 50°F 21°/ 10°C	90°/ 70°F 32°/ 21°C		
AIR COOLED	KDT-0300A	kube	330 lbs.	230 lbs.	5.9 ★	19 Gal.
			150 kgs	104 kgs		71.9 L
	KYT-0300A	half-kube	330 lbs.	230 lbs.	5.9 ★	19 Gal.
			150 kgs	104 kgs		71.9 L

Order ice machine and bin separately
★ indicates Energy Star 3.0 certified

Shipping Weight:

Air-cooled: 146 lbs (66kg)
Water-cooled: 153 lbs (69 kg)



Accessories

Dispenser Bin Thermostat Kit
Reduces condensation when used with dispensers.



Top Air Discharge Kit
Convert air flow to rear in-take / top exhaust.



Arctic Pure® Water Filters
Reduces sediment and chlorine odors for better tasting ice.



Clean Air Pack
Chlorine dioxide sachet to inhibit bacteria growth.



Welbilt reserves the right to make changes to the design or specifications without prior notice.