

KT-1700 Ice Kube Machine

KT-1700 ICE KUBE MACHINE

Models

- KDT-1700A
 KYT-1700A
 KDT-1700W
 KYT-1700W
 KDT-1700N
 KYT-1700N



Koolaire KT-1700
Ice Kube Machine on K970 Bin

Koolaire by Manitowoc ice machines are designed, developed and tested by Manitowoc engineers to provide great ice production, energy efficiency and reliable service at an affordable price.

Performance/Features/Benefits

- Produces up to 1740 lbs (789 kg) of ice per day**
- Performance certified by the Air Conditioning, Heating and Refrigeration Institute (AHRI)
- Energy Efficient models - visit EnergyStar.gov to view all Energy Star qualifying models
- Highly efficient electro-less nickel plated copper evaporators made in Manitowoc WI, USA
- Simple operation - only one control, three positions ON/OFF/CLEAN
- High-Tech exterior with smudge and fingerprint resistant stainless-like finish
- Better for the environment. Uses R410A refrigerant which lowers global warming potential by 48%
- Backed by the industry's best Manitowoc distribution network and service agents

Built for Easy Sanitation

- Easy access front facing evaporator
- One-touch remedial cleaning; requires minimal interaction; just add chemical and let the machine do the rest. No ice removal from bin needed. (Use Manitowoc De-scaler and Sanitizer only)
- For detail cleaning; all food zone components removable by hand (no tools required). Fast and easy
- All white plastic interior, no exposed tubes or wires, smooth rounded corners for fast easy wipe downs
- The food zone is sealed from above and on the back of the door panel with commercial grade rubber gaskets
- Alpha San anti-microbial agent molded in selected components
- Additional sanitation protection available with CleanAir™ packs to control the growth of bacteria, fungi and slime inside the food zone

**based on 70F air / 50F water

Ice Machine Electric

203-208V / 60Hz / 1Ph

Minimum circuit ampacity:

- Air-cooled: 18.1
 Water-cooled: 16.5
 Remote Air-cooled: 15.2

Maximum fuse size:

- Air-cooled: 30 amps
 Water-cooled: 25 amps
 Remote Air-cooled: 25 amps

Specifications

BTU Per Hour:
23,400 (average)
and 25,200 (peak)

Refrigerant:
R410A CFC - Free
Lowers global warming
by 48%

Operating Limits:

- Ambient Temperature Range: 40° to 110° F (4.4° to 43.3° C)
- Water Temperature Range: 40° to 90° F (4.4° to 32.2° C)
- Water Pressure Ice Maker Water In: Min. 20 psi (137.9 kPa) Max. 80 psi (551.1 kPa)

Ice Shape



HALF KUBE
3/8" x 1 1/8" x 7/8"
(.95 x 2.86 x 2.22 cm)

❄️ = 100%



KUBE
7/8" x 7/8" x 7/8"
(2.22 x 2.22 x 2.22 cm)

❄️ = 100%



KT1700 on K-970 Storage Bin

Required Clearance:
Top/Sides: 8" (20.3 cm)
Back: 5" (12.7 cm)

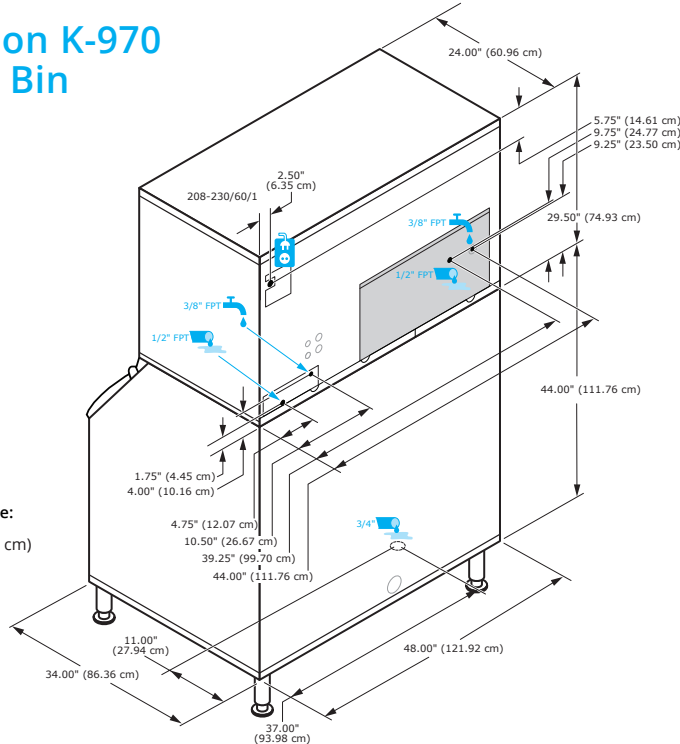

Water cooled condenser water usage/100 lbs. or 45.5 Kg. of ice: 145 gals. / 549L.

Space-Saving Design



KT1700
K-970

Height 79.5"
202.93 cm
Width 48.00"
121.92 cm
Depth 34.00"
86.30 cm
Bin Storage 882 lbs.
400 kgs.

Measurements with bin legs at 6.00" (15.24cm).
Adjustable bin legs 6.00" to 8.00" (15.24cm to 20.32cm).
Bin capacity is based on 90% of the volume x 33 lbs/ft³ average density of ice.

Specifications

| | Model | Ice Shape | Ice Production 24 Hours | | Power Usage kWh/100 lbs. @90°Air/70°F | Potable Water Usage/100 lbs. 45.4 kgs. of Ice |
|---------------|-----------|-----------|-------------------------|------------------------|--|---|
| | | | 70°/ 50°F 21°/ 10°C | 90°/ 70°F 32°/ 21°C | | |
| AIR COOLED | KDT-1700A | kube | 1652 lbs. | 1326 lbs. | 4.70 | 20 Gal. 75.7 L |
| | | half-kube | 749 kgs | 601 kgs | | |
| WATER COOLED | KYT-1700A | kube | 1652 lbs. | 1334 lbs. | 4.66 | 20 Gal. 75.7 L |
| | | half-kube | 749 kgs | 605 kgs | | |
| REMOTE COOLED | KDT-1700W | kube | 1600 lbs. | 1400 lbs. | 3.61 | 20 Gal. 75.7 L |
| | | half-kube | 726 kgs | 635 kgs | | |
| WATER COOLED | KYT-1700W | kube | 1555 lbs. | 1421 lbs. | 3.49 | 20 Gal. 75.7 L |
| | | half-kube | 705 kgs. | 645 kgs | | |
| REMOTE COOLED | KDT-1700N | kube | 1680 lbs | 1380 lbs | 4.26 | 20 Gal. 75.7 L |
| | | half-kube | 762 kg | 626 kg | | |
| WATER COOLED | KYT-1700N | kube | 1740 lbs | 1477 lbs | 4.06 ★ | 20 Gal. 75.7 L |
| | | half-kube | 789 kg | 670 kg | | |

Order ice machine and bin separately.

For "N" models order Manitowoc JCT1500-261 remote condenser.

★ indicates Energy Star 3.0 certified.

Shipping Weight:

Air-cooled: 333 lbs (151 kg)
Water-cooled: 337 lbs (153 kg)
Remote Air-cooled: 311 lbs (141 kg)



Accessories

Dispenser Bin Thermostat Kit
Reduces condensation when used with dispensers.



Top Air Discharge Kit
Convert air flow to rear in-take / top exhaust.

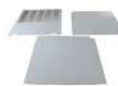

Arctic Pure® Water Filters
Reduces sediment and chlorine odors for better tasting ice.



Clean Air Pack
Chlorine dioxide sachet to inhibit bacteria growth.



Welbilt reserves the right to make changes to the design or specifications without prior notice.