



SR48A-12D2

Sandwich Top 48" Prep Refrigerator with One Door and Two Drawers



SR48A-12D2
02/05/20
Item # 13475

W x D x H
48" x 30" x 44.25"*
*with 6" casters



Item #: _____
Project: _____
Qty: _____
AIA#: _____

Features

► Engineered to maintain NSF-7 temperatures in 100°F ambient. (Certified to NSF-7 temperatures in 86°F ambient.)

► Stainless steel exterior front, sides and top with stainless steel interior sides, back, and floor

► Front breathing air flow design

- Environmentally friendly R290 hydrocarbon refrigerant
- Cabinet, doors, and drawers are insulated with 2" CFC free, foamed in place polyurethane
- Innovative air distribution system distributes air evenly to maintain product temperature
- Provided with a full complement of polycarbonate plastic 1/6th size pans, 4" deep and adapter bars
- Rails will also accept 6" deep pans for 50% more pan volume
- 48" x 10" x 1/2" thick white polyethylene cutting board is standard
- Drawer slides are constructed of 16 gauge stainless steel with acetal rollers
- Drawer frames are formed of 16 gauge stainless steel and securely fastened in the cabinet
- Top and bottom drawers will accommodate (1) 1/2 size pan & (1) 1/3 size pan. In addition, top drawer will also accommodate (1) 1/4 size pan and (1) 1/6 size pan. Alternate pan orientation (top drawers only) provides (1) full size pan positioned longways front to back and (3) 1/9 size pans.
- One epoxy coated shelf per door section is standard
- Extruded aluminum flush mount drawer handle
- Magnetic door gasket is easily removable for cleaning
- Removable stainless steel prep guard simplifies cleanup from accidental rail pan drips and spills
- E-coated evaporator coil
- Standard with 6" stem casters (two with brakes)
- 10 ft. cord and plug

Note: Made to order. Allow 4-6 weeks.

Door or drawer can be located in any section of the cabinet. Location must be indicated at time of ordering.

Hoshizaki reserves the right to change specifications without notice.



Dimensions / Capacity

Interior Storage Capacity (CF)	13.66 ft ³
Interior Storage Capacity (CF) (AHAM)	11.95 ft ³
Overall Width x Depth (including 1" bumper)	48" x 31"
Height (including 6" casters)	44.25"
Depth with Cutting Board Installed	30.7"
Door Opening Width x Height	19.5" x 23"
Depth with Drawer Fully Open (including 1" bumper)	50.25"
Depth with Door Open at 90° (including 1" bumper)	52.5"
Pan Capacity (# of 1/6 size x 4" deep)	12
Adjustable Shelves / Shelf Dimensions W x D	1 / 21.25" x 16"
Crated Shipping Weight	335 lbs.
Crated Length x Width x Height	51" x 32" x 46"

Two-Section SR48A-12D2

Electrical / Refrigeration

Voltage	115/60/1
HACR Breaker	15.0 Amps
Electrical Connection (NEMA)	5-15P Ⓢ
Voltage Range	104-126
Ambient Temp. Range	45° to 100°F
Control Setpoint Range	32° to 52°F
Amperage	2.5
Energy Consumption (kWh/day) @NSF	3.2
Heat Rejection (BTU/Hr.) @NSF	452.3
Approx. Nominal Compres. BTU/HR (HP)	1354(1/5HP)
Refrigerant / Charge Amount (oz)	R290(2.9 oz)

Two-Section SR48A-12D2

Options

- 2.25" Casters
- 4" Casters
- Stainless steel lift off covers
- Additional Epoxy Shelves
- Composite cutting board (HS-5267)
- Stainless steel back
- Overshelves
- Drawer divider bars
- Rail adapter bars
- Stainless steel shelves

Warranty

- * 3 Year - Parts and Labor on entire machine.
- 5 Year - Parts on Compressor
- Valid in United States, Canada, Puerto Rico and U.S. Territories. Contact factory for warranty in other countries.



SR48A-12D2

Sandwich Top 48" Prep Refrigerator with One Door and Two Drawers



SR48A-12D2
02/05/20
Item # 13475

FRONT VIEW

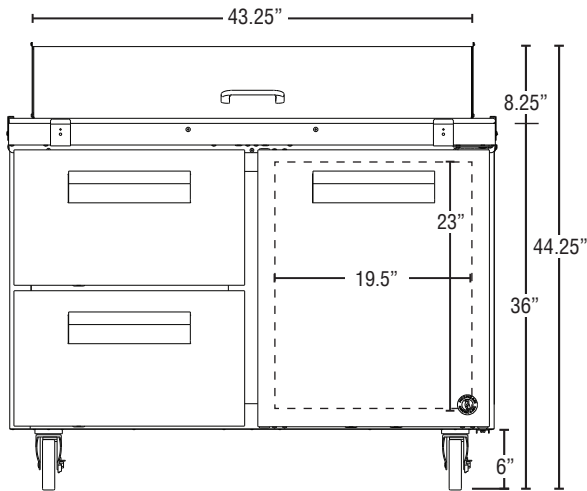

SIDE VIEW

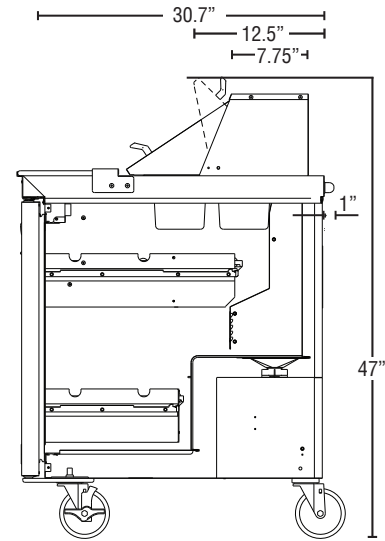

PLAN VIEW

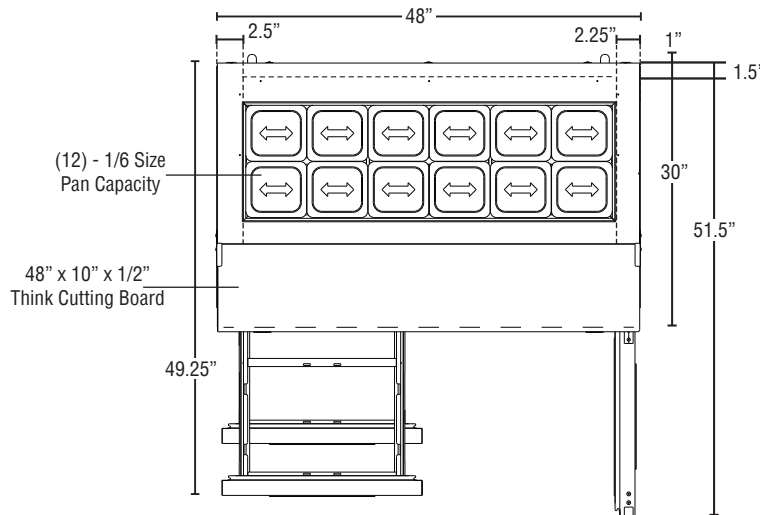

Cabinet Construction

The exterior cabinet top, front, and sides, are constructed of high quality stainless steel. Cabinet is provided with a stainless steel top enclosure and an easily removable stainless steel insulated lift-up cover. The exterior back and bottom are constructed of coated steel. The cabinet interior back and sides are stainless steel with an ABS ceiling and stainless steel floor. One heavy duty epoxy coated shelf per section is standard. Mounted on anodized aluminum pilasters the shelf is adjustable in 1/2" increments. Cabinet walls are insulated with 2" of environmentally friendly, CFC free, foamed in place polyurethane. 6" polyolefin, stem casters (two with brakes) are standard. Preparation tables are supplied with a 48" x 10" x 1/2" thick N.S.F. approved white polyethylene cutting board.

Drawer Construction

Drawer fronts are constructed of high grade stainless steel inside with stainless steel interior liners and are insulated with 2" CFC free, foamed in place polyurethane. The bottom drawers will accommodate 6" deep pans. Full size pans in the top drawer can be oriented longways from front to back. The top drawer will accommodate 4" deep pans with either orientation. The top drawer will also accommodate (1) 1/2 size pan & (1) 1/3 size pan 6" deep at the front of the drawer opening and provide capacity for (1) 1/4 size pan and (1) 1/6 size pan 4" deep in the rear of the drawer. HS-5432 is recommended for this configuration. The drawer slides are constructed of heavy duty 16 gauge stainless steel and durable acetal rollers with stainless steel ball bearings to prevent metal to metal contact. The drawer slides have a dynamic load capacity of 175 lbs. and have been life tested (fully loaded) three hundred thousand openings and closings without showing significant wear.

Door Construction

Doors are constructed of high grade stainless steel exterior with an ABS interior liner and are insulated with 2" CFC free, foamed in place polyurethane. Hoshizaki's exclusive "stepped" design protects the gasket while product is removed from the cabinet. Doors are provided with a one piece, extruded aluminum, flush mount handle. Spring assisted self-closing doors are equipped with a stay open feature past 90 degrees. Snap-in magnetic door gaskets are durable and easily removed for cleaning. Field reversible door hinging is standard.

Refrigeration System

Front breathing refrigeration system allows unit to be built in to any enclosure with zero side or rear clearance. The high efficiency refrigeration system is self-contained with an E-coated evaporator for extended life. Condensate removal is accomplished with an energy efficient non-electric evaporation system. A capillary tube controls the flow of environmentally friendly R290 refrigerant through the evaporator. Refrigeration system utilizes a heated defrost to eliminate any ice on the evaporator coil. An innovative air distribution system distributes air evenly around the pans. Engineered to maintain NSF-7 temperatures in 100°F ambient. (Certified to NSF-7 temperatures in 86°F ambient.) Preparation tables are supplied with a full complement of N.S.F. approved plastic 1/6 size pans, 4" deep and stainless steel adapter bars. Rail will also accommodate 6" deep pans. Pans are located 1.5" below the top to keep food product within easy reach. 115 volt units are equipped with a ten foot cord and NEMA rated plug (20.0 amps or less).