

## 74" Five Pan Sealed Well Electric Hot Food Steam Table - 240V, 3700W

### FEATURES

- Stainless steel structure with individual valves
- Enclosed base cabinet with sliding doors
- Polyethylene cutting board
- Adjustable stainless steel feet
- Stainless steel heating element
- Independent infinite controls
- Pans sold separately

Perfect storage space for this steam table with enclosed base, sliding door with recessed handle allows for easy to access. No spillage pans required for sealed well steam table, allowing customer directly add water to the well. Built-in water drain make it easy for cleaning after service.



### Optional Lighted Sneeze Guard

- 74" lighted heated sneeze guard
- Four side tempered glass
- Includes five heat lamp bulbs
- Prevents contamination

This 74" food service glass sneeze guard display features stainless steel frame with four sides tempered glass, allowing customers excellent views of your food from all angles. The standard 120V makes set up easy.



**U**SR Brands is a US supplier of premium quality commercial cooking, refrigeration and food preparation equipment. Our aim is simple. Produce industry-leading commercial restaurant equipment at reasonable prices, and back it all up with an easy to understand, no nonsense warranty that people can count on.

Project:	Quantity:
Model #:	Approval:

For Commercial Use Only

## TECHNICAL DATA

MODEL	Exterior Dimension	Volts/Hertz	Watts	Plug	Number of Well	Well Type	Body Type
ESTC74-5S	73.8" x 30.6" x 34.4"	208~240V/60HZ	3700W	NEMA 6-20P	5	Sealed Well	Cabinet

## TECHNICAL DRAWING

FRONT

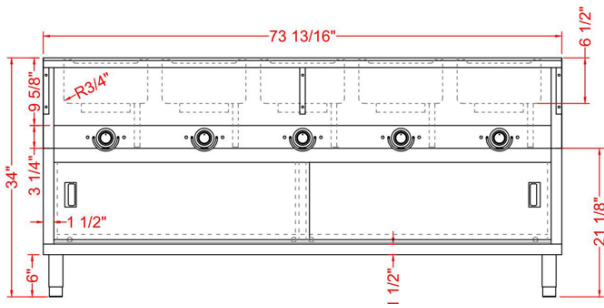

SIDE

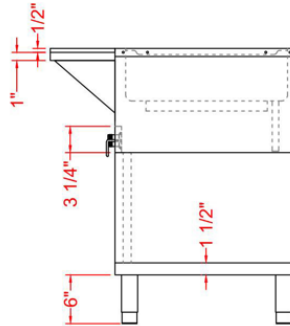

TOP

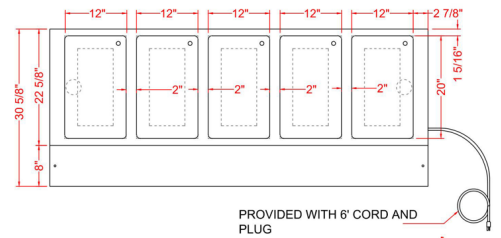

### Optional Lighted Sneeze Guard

FRONT

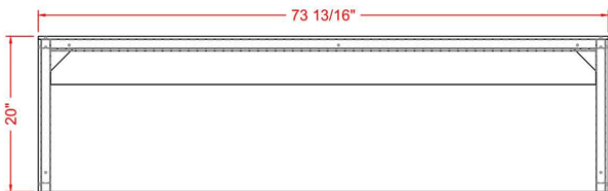

SIDE

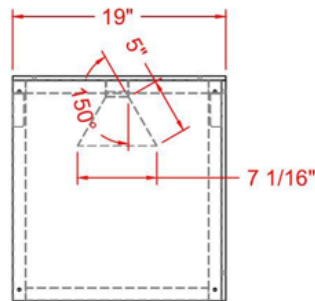

TOP

