

| | |
|----------|-----------|
| Project: | Quantity: |
| Model #: | Approval: |

For Commercial Use Only

48" Three Well Electric Hot Food Steam Table with Undershaft - 120V, 1500W

FEATURES

- Removable 1/2" thick poly cutting board
- Stainless steel construction
- Stainless steel heating element
- Undershaft included
- Legs included, casters optional
- Fiberglass insulation between wells
- Adjustable stainless steel feet
- Independent heat controls
- No plumbing or drain needed
- Open well design for water (spillage pans sold separately) or dry heat



Optional Lighted Sneeze Guard

- 48" Lighted Heated Sneeze Guard
- Four side tempered glass
- Includes three heat lamp bulbs
- Prevents contamination

This 48" food service glass sneeze guard display features stainless steel frame with four sides tempered glass, allowing customers excellent views of your food from all angles. The standard 120V makes set up easy.



USR Brands is a US supplier of premium quality commercial cooking, refrigeration and food preparation equipment. Our aim is simple. Produce industry-leading commercial restaurant equipment at reasonable prices, and back it all up with an easy to understand, no nonsense warranty that people can count on.

TECHNICAL DATA

| MODEL | Exterior Dimension | Number of Well(s) | Electrical | Plug Type | Power | Well Type | Body Type |
|----------|---------------------|-------------------|---------------|------------|-------|-----------|------------|
| EST48-30 | 48" x 30.6" x 34.4" | 3 | 120v/60hz/1ph | NEMA 5-15P | 1500w | Open Well | Undershelf |

TECHNICAL DRAWING

SKU: EST48-30
MFR ITEM #: EST-3OW-US

FRONT

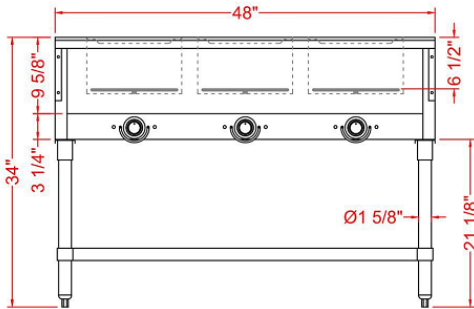

SIDE

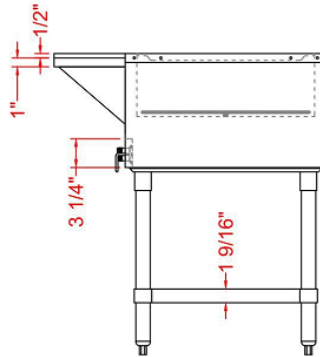

TOP

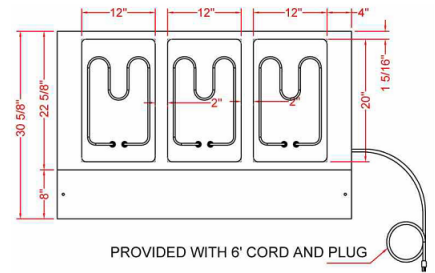

Optional Lighted Sneeze Guard

FRONT

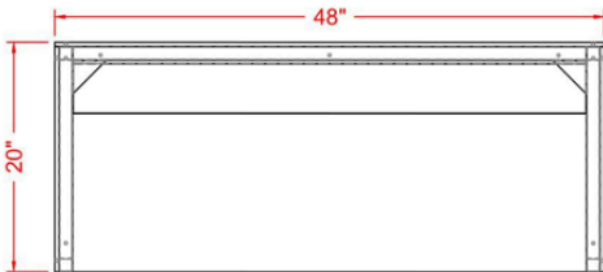

SIDE

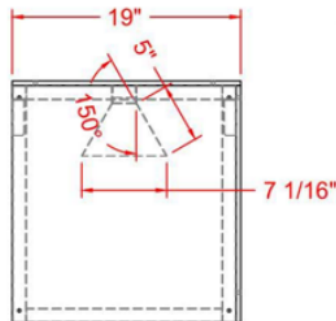

TOP

