

Two Well Electric Hot Food Steam Table with Undershef - 120V, 1000W

FEATURES

- Removable 1/2" thick poly cutting board
- Stainless steel construction
- Stainless steel heating element
- Undershef included
- Legs included, casters optional
- Fiberglass insulation between wells
- Adjustable stainless steel feet
- Independent heat controls
- No plumbing or drain needed
- Open well design for water (spillage pans sold separately) or dry heat



Optional Sneeze Guard

- Stainless steel construction
- For steamtables, salad bars, counters
- Protects food on 3 sides
- Easy to clean

Protect your food while still allowing your customers to see your product! Stainless steel frame are easy to clean and built to last.



USR Brands is a US supplier of premium quality commercial cooking, refrigeration and food preparation equipment. Our aim is simple. Produce industry-leading commercial restaurant equipment at reasonable prices, and back it all up with an easy to understand, no nonsense warranty that people can count on.

TECHNICAL DATA

MODEL	Exterior Dimension	Number of Well(s)	Electrical	Plug Type	Power	Well Type	Body Type
EST30-20	31.8" x 30.6" x 34.4"	2	120v/60hz/1ph	NEMA 5-15P	1000w	Open Well	Undershelf

TECHNICAL DRAWING

SKU: EST30-20
MFR ITEM #: EST-2OW-US

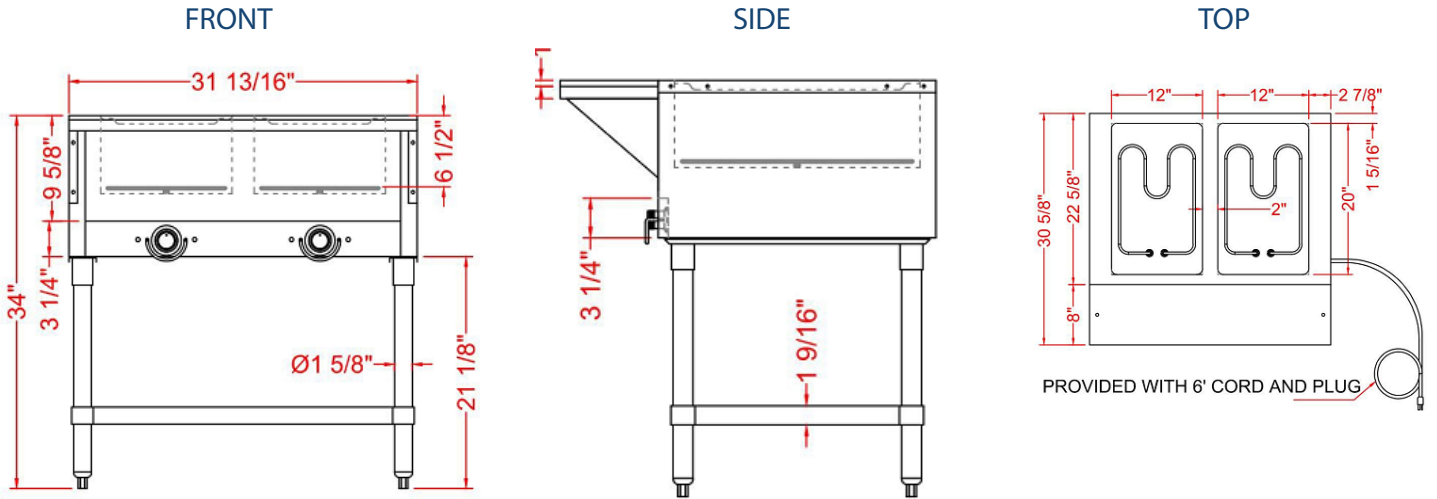

Optional Sneeze Guard

