



# BEVERAGE-AIR

Project: \_\_\_\_\_

AIA#

Item: \_\_\_\_\_

Location: \_\_\_\_\_

SIS#

Approved: \_\_\_\_\_

## WTRD REFRIGERATORS WITH DRAWERS

WTRD36AHC Two Drawer Worktop Refrigerators  
Hydrocarbon Series

MODELS:  
WTRD36AHC-2



WTRD36AHC-2

**3 Year Parts/Labor Warranty**  
**Additional 2 Year Compressor Warranty**

### CABINET CONSTRUCTION

- Stainless steel front, sides and drawers (*galvanized back & bottom*)
- Interior liner is made of corrosion resistant aluminum
- Stainless steel worktop for added durability
- Full electronic control
- Interior thermometer is standard
- 4" Removable backslash for flexibility and ease of cleaning
- Painted aluminum drawer handles
- Snap-in drawer gaskets
- Upper and lower pull-out drawers accommodate 6" deep pans
- Stainless steel drawer frames supported on telescoping drawer slides
- Drawer slides include locking mechanism that prevents drawer from being inadvertently pulled off cabinet
- 6" Casters, two (2) with brakes standard
- Maintains product temperature between 36°F and 38°F

### OPTIONS & ACCESSORIES

- Stainless steel back and grille
- Stainless steel interior
- Cutting board
- 3" Casters or 6" legs
- Low profile casters
- Remote option

### REFRIGERATION SYSTEM

- Refrigeration system uses R290 refrigerant to comply with all environmental concerns
- Automatic, non-electric defrost
- Epoxy coated evaporator coil

WTRD36AHC Refrigerators With Drawers: Worktop Series



3779 Champion Blvd., Winston-Salem, NC 27105  
1-888-845-9800 Fax: 1-336-245-6453  
Beverage-Air.com sales@bevair.com



# BEVERAGE-AIR

## Worktop Refrigerators – With Drawers

Models: WTRD36AHC-2

MODEL	WTRD36AHC-2
<b>EXTERNAL DIMENSIONAL DATA</b>	
Width Overall	36"
Depth Overall with Handle & Bumper	32 1/4"
Height Overall with 6" Casters	39 5/8"
Depth with Drawer Extended	47 1/2"
Drawer Opening (in)	(2) 31 5/8" x 9 3/8"
<b>INTERNAL DIMENSIONAL DATA</b>	
NET Capacity (cubic ft.)	8.5
Internal Width Overall (in)	32"
Internal Depth Useable (in)	15 3/8"
Internal Height Overall (in)	23"
Number of Drawers	2
<b>ELECTRICAL DATA</b>	
Full Load Amperes 115/60/1	2.0
<b>REFRIGERATION DATA</b>	
Horsepower	1/6
Capacity (BTU/Hr)*	1094
<b>WEIGHT DATA</b>	
Gross Weight (Crated lbs)	244 lbs
Height - Crated	35"
Width - Crated	38"
Depth - Crated	33"

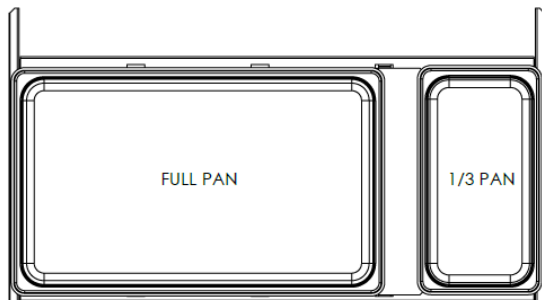

**Model Views**

**Plan View**

**Elevation View**

**Side View**

### ELECTRICAL CONNECTION



115/60/1  
NEMA-5-15P

Units pre-wired at factory and include 8' long cord and plug set.



an Ali Group Company



The Spirit of Excellence

3779 Champion Blvd., Winston-Salem, NC 27105  
1-888-845-9800 Fax: 1-336-245-6453  
Beverage-Air.com sales@bevair.com