



# BEVERAGE-AIR

Project: _____	AIA#
Item: _____	
Location: _____	SIS#
Approved: _____	

## SHALLOW DEPTH WORKTOP REFRIGERATOR

MODEL:  
WTR34HC-FIP

WTR34HC Solid Door With Foamed-In Place Backsplash  
Hydrocarbon Series



**3 Year Parts/Labor Warranty**  
**Additional 4 Year Compressor Warranty**

### CABINET CONSTRUCTION

- Stainless steel front, sides, door and grille (galvanized back & bottom)
- Interior liner is made of corrosion resistant aluminum
- Stainless steel top for added durability
- Full electronic control
- Interior thermometer is standard
- Foamed-in place backsplash
- Self-closing door with 120° stay-open feature, on lift-off style hinges
- Easy door removal for service and cleaning
- Magnetic gasket attached to each door for positive seal
- 6" Casters, two (2) with brakes standard
- Two epoxy-coated steel wire shelves standard
- Field-reversible door (hinge kit not included)

### OPTIONS & ACCESSORIES

- Stainless steel back
- Stainless steel interior
- 16 Gauge stainless steel top
- Additional shelves
- Shelf clips
- Glass door option
- Right or left hinged door
- Locks (solid doors only)
- Wire shelf divider
- Cutting board
- 3" Casters
- 6" legs (stainless steel, black or seismic/flange)
- Low profile casters
- Roller kit
- Remote option\* (see note on back on page)

### REFRIGERATION SYSTEM

- Uses environmentally friendly, energy efficient R290 refrigerant, and meets all regulatory requirements for CARB, SNAP, DOE & more
- Adaptive defrost
- Epoxy coated evaporator coil
- Refrigerators capable of maintaining product temperature between 36°F and 38°F

**WTR34HC WORKTOP REFRIGERATOR**



Please verify qualifying units by visiting:  
[www.energystar.gov/cfs](http://www.energystar.gov/cfs)

3779 Champion Blvd., Winston-Salem, NC 27105  
1-888-845-9800 Fax: 1-336-245-6453  
Beverage-Air.com Sales@bevair.com



# BEVERAGE-AIR

MODEL	WTR34HC-FIP
<b>EXTERNAL DIMENSIONAL DATA</b>	
Width Overall	34"
Depth Overall with Handle & Bumper	24 <sup>5</sup> / <sub>8</sub> "
Height Overall with 6" Casters	36 <sup>1</sup> / <sub>8</sub> "
Number of Doors	2
Depth with Door Open 90°	38 <sup>1</sup> / <sub>8</sub> "
Door Opening	13 <sup>1</sup> / <sub>8</sub> " x 18"
<b>INTERNAL DIMENSIONAL DATA</b>	
NET Capacity (cubic ft.)	5.96
Internal Width Overall	30"
Internal Depth Overall	8 <sup>1</sup> / <sub>8</sub> "
Internal Height Overall	19 <sup>1</sup> / <sub>2</sub> "
Number of Shelves	2
<b>ELECTRICAL DATA</b>	
Full Load Amperes	2.0
<b>REFRIGERATION DATA</b>	
Horsepower	1/10
Capacity (BTU/Hr)	1110
<b>SHIPPING DATA</b>	
Gross Weight - Crated	190 lbs
Height - Crated	43"
Width - Crated	30"
Depth - Crated	32"

\*NOTE: Remote units are field wired and come with 6" legs.  
Refrigerant must be specified at time of order.

## Worktop Refrigerator - Shallow Depth Models: WTR34HC-FIP

### Model Views

Required Clearance: 3 3/16" bottom & 2" rear

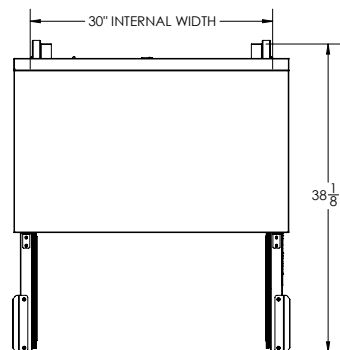

### PLAN VIEW

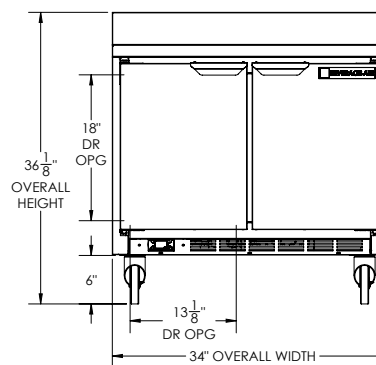

### ELEVATION VIEW

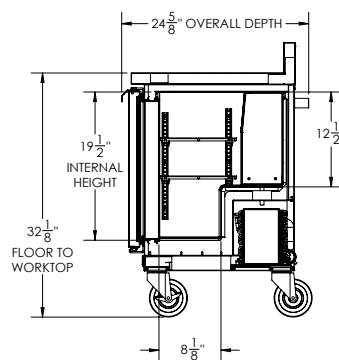

### SIDE VIEW

### \*ELECTRICAL CONNECTION



115/60/1  
NEMA 5-15P

Unit pre-wired at  
factory and include 8'  
long cord and plug set.



3779 Champion Blvd., Winston-Salem, NC 27105 1-888-845-9800 Fax: 1-336-245-6453 Beverage-Air.com Sales@bevoir.com

an Ali Group Company



The Spirit of Excellence