



BEVERAGE-AIR

Project: _____	AIA#
Item: _____	
Location: _____	SIS#
Approved: _____	

WORKTOP REFRIGERATOR

MODEL:
WTR32AHC-FIP

WTR32AHC Solid Door With Foamed-In Place Backsplash
Hydrocarbon Series



3 Year Parts/Labor Warranty
Additional 4 Year Compressor Warranty

CABINET CONSTRUCTION

- Stainless steel front, sides, door and grille (galvanized back & bottom)
- Interior liner is made of corrosion resistant aluminum
- Stainless steel top for added durability
- Full electronic control
- Interior thermometer is standard
- Foamed-in place backsplash
- Self-closing doors with 120° stay-open feature, on cartridge style hinges
- Magnetic gasket attached to each door for positive seal
- 6" Casters, two (2) with brakes standard
- Two epoxy-coated steel wire shelves
- Field-reversible door (hinge kit not included)

OPTIONS & ACCESSORIES

- Stainless steel back
- Stainless steel interior
- 16 Gauge stainless steel top
- Additional shelves
- Shelf clips
- Glass door option
- Right or left hinged door
- Locks (solid doors only)
- Wire shelf divider
- Cutting board
- 3" Casters
- 6" legs (stainless steel, black or seismic/flange)
- Low profile casters
- Roller kit
- Remote option* (see note on back on page)

REFRIGERATION SYSTEM

- Uses environmentally friendly, energy efficient R290 refrigerant, and meets all regulatory requirements for CARB, SNAP, DOE & more
- Adaptive defrost
- Epoxy coated evaporator coil
- Refrigerators capable of maintaining product temperature between 36°F and 38°F

WTR32AHC WORKTOP REFRIGERATOR



Please verify qualifying units by visiting:
www.energystar.gov/cfs

3779 Champion Blvd., Winston-Salem, NC 27105
1-888-845-9800 Fax: 1-336-245-6453
Beverage-Air.com Sales@bevair.com



BEVERAGE-AIR

MODEL	WTR32AHC-FIP
EXTERNAL DIMENSIONAL DATA	
Width Overall	32"
Depth Overall with Handle & Bumper	32"
Height Overall with 6" Casters	39 1/2"
Number of Doors	1
Depth with Door Open 90°	60 1/8"
Door Opening	27 5/8" x 21 5/8"
INTERNAL DIMENSIONAL DATA	
NET Capacity (cubic ft.)	7.2
Internal Width Overall (in)	28"
Internal Depth Overall (in)	15 3/8"
Internal Height Overall (in)	23"
Number of Shelves	2
ELECTRICAL DATA	
Full Load Amperes	2.0
REFRIGERATION DATA	
Horsepower	1/10
Capacity (BTU/Hr)	1110
SHIPPING DATA	
Gross Weight - Crated	232 lbs
Height - Crated	36"
Width - Crated	40"
Depth - Crated	32"

*NOTE: Remote units are field wired and come with 6" legs. Refrigerant must be specified at time of order.

Worktop Refrigerator Models: WTR32AHC-FIP

Model Views

Required Clearance: 3 3/16" bottom & 2" rear

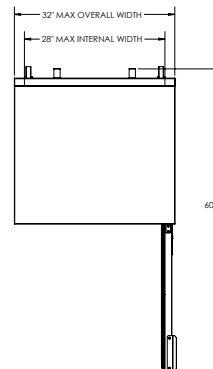

PLAN VIEW

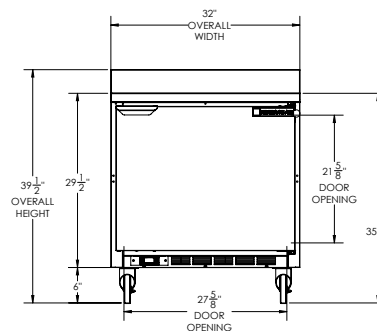

ELEVATION VIEW

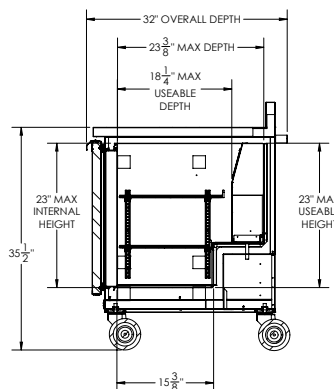

SIDE VIEW

*ELECTRICAL CONNECTION



115/60/1
NEMA 5-15P

Unit pre-wired at factory and include 8' long cord and plug set.



3779 Champion Blvd., Winston-Salem, NC 27105 1-888-845-9800 Fax: 1-336-245-6453 Beverage-Air.com Sales@bevoir.com

an Ali Group Company



The Spirit of Excellence