



# BEVERAGE-AIR

Project: _____	AIA#
Item: _____	
Location: _____	SIS#
Approved: _____	

## CT MERCHANDISER SERIES

CF3HC Countertop Freezer  
Hydrocarbon Series

MODEL:  
CF3HC-1-W



**1 Year Parts/Labor Warranty**

### CABINET CONSTRUCTION

- White powder coated paint steel exterior
- Interior white painted steel for easy cleaning
- Triple pane glass
- 2 Shelves standard, adjustable one full and one half shelf
- Unit standard with leveling legs which are 2" high, legs can be adjusted up to 1" for leveling of the freezer
- LED lighting standard
- Freezer operating temperature is -10°F - 0°F

### OPTIONS & ACCESSORIES

- Custom Graphics

### REFRIGERATION SYSTEM

- Refrigeration system uses R290 refrigerant to comply with all
- Cold wall evaporator
- The unit is best suited for an environment where temperatures remain below 75°F and humidity does not exceed 55%.

**CF3HC Countertop Freezer: Merchandiser Series**



3779 Champion Blvd., Winston-Salem, NC 27105  
1-888-845-9800 Fax: 1-336-245-6453  
Beverage-Air.com Sales@bevair.com



# BEVERAGE-AIR.

MODEL	CF3HC-1-W
<b>EXTERNAL DIMENSIONAL DATA</b>	
Width Overall	23.7"
Depth Overall	23.9"
Height Overall Height excludes leveling legs	29.2"
Number of Doors	1
<b>INTERNAL DIMENSIONAL DATA</b>	
NET Capacity (cubic ft.)	2.9
Number of Shelves	2
<b>ELECTRICAL DATA</b>	
Full Load Amperes 115/60/1	4
<b>REFRIGERATION DATA</b>	
Horsepower	1/4
<b>WEIGHT DATA</b>	
Gross Weight (Crated lbs)	120 lbs
Height - Crated	33"
Width - Crated	26"
Depth - Crated	26"

## Countertop Freezer Model:CF3HC-1-W

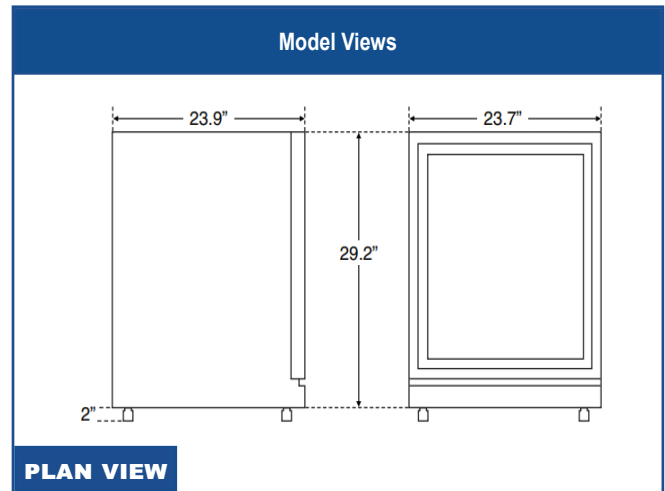

### \*ELECTRICAL CONNECTION



NEMA 5-15P

Units pre-wired at factory and include cord and plug set.



3779 Champion Blvd., Winston-Salem, NC 27105 1-888-845-9800 Fax: 1-336-245-6453 Beverage-Air.com Sales@bevair.com

an Ali Group Company



The Spirit of Excellence