



BEVERAGE-AIR

Project: _____	AIA#
Item: _____	
Location: _____	SIS#
Approved: _____	

HORIZON TOP MOUNT REACH-IN

HR3HC Half-Solid Triple Door Reach-In Refrigerator

Hydrocarbon Series

MODEL:
HR3HC-1HS

HR3HC TOP MOUNT REACH-IN REFRIGERATOR

3 Year Parts/Labor Warranty
Additional 4 Year Compressor Warranty



CABINET CONSTRUCTION

- Exterior is stainless steel front and gray painted sides
- Interior liner is made of corrosion resistant aluminum
- Full electronic control
- One piece grille
- LED interior light
- Self-closing door with 120° stay-open feature, on cam-lift hinges
- Field reversible doors
- Door locks
- Snap-in magnetic gaskets for positive door seal
- Nine (9) heavy-duty epoxy coated wire shelves
- 6" Heavy-duty casters, two (2) with brakes
- 8' Cord and plug (see electrical data for details)

OPTIONS & ACCESSORIES

- Tray slide pair, 1 tray slide set for (1) 18" x 26" or (2) 14" x 18" pans (A)
- Stainless steel universal tray slide pair, 1 tray slide set for (1) 18" x 26" or (2) 14" x 18" pans (AC)
- Tray slide kit #4 (19 sets per half section)
- Additional shelves
- Shelf clips
- Stainless steel breaker
- 6" Legs seismic/flanged
- 3" Casters
- Remote option* (see note on back page)

FINISH OPTIONS

- **HR Standard**
(S/S front, continuous coil coated sides, aluminum interior)
- **HRP**
(S/S front, S/S sides, aluminum interior)
- **HRS**
(S/S front, continuous coil coated sides, S/S interior)
- **HRPS**
(Complete S/S exterior & interior)

REFRIGERATION SYSTEM

- Uses environmentally friendly, energy efficient R290 refrigerant, and meets all regulatory requirements for CARB, SNAP, DOE & more
- Hot gas condensate evaporator
- Adaptive defrost
- Epoxy coated evaporator coil
- Maintains product temperatures between 36°F and 38°F



Please verify qualifying units by visiting:
www.energystar.gov/cfs

3779 Champion Blvd., Winston-Salem, NC 27105
1-888-845-9800 Fax: 1-336-245-6453
Beverage-Air.com Sales@bevair.com



BEVERAGE-AIR

MODEL	HR3HC-1HS
EXTERNAL DIMENSIONAL DATA	
Width Overall	78"
Depth Overall with Handle	33 ⁵ / ₈ "
Height Overall	85"
Number of Doors	6
Depth with Door Open 90°	55 ¹ / ₈ "
Door Opening (in)	21 ⁵ / ₈ " x 29 ⁵ / ₈ "
INTERNAL DIMENSIONAL DATA	
NET Capacity (cubic ft.)	71.52
Internal Width Overall (in)	74"
Internal Depth Overall (in)	25 ⁷ / ₈ "
Internal Height Overall (in)	62"
Number of Shelves	9
ELECTRICAL DATA	
Full Load Amperes 115/60/1	6.0
REFRIGERATION DATA	
Capacity (BTU/Hr)*	2800
Horsepower	1/3
SHIPPING DATA	
Gross Weight (crated lbs)	791 lbs
Height - Crated	88"
Width - Crated	80"
Depth - Crated	36"

*NOTE: Remote units are field wired and come with 6" legs.
Refrigerant must be specified at time of order.

Top Mount Reach-In Refrigerator Model: HR3HC-1HS

Model Views

Required Clearance: Top 12", Rear 3"

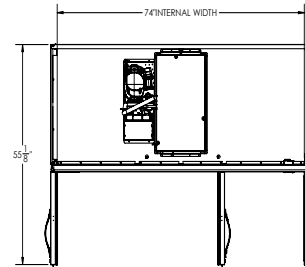

PLAN VIEW

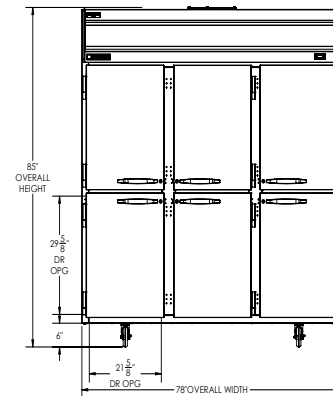

ELEVATION VIEW

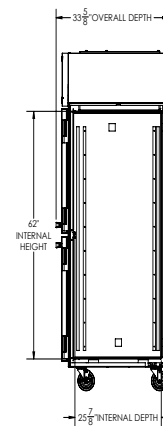

SIDE VIEW

*ELECTRICAL CONNECTION



115/60/1
NEMA 5-15P

Unit pre-wired at factory and include 8' long cord and plug set.



3779 Champion Blvd., Winston-Salem, NC 27105 1-888-845-9800 Fax: 1-336-245-6453 Beverage-Air.com Sales@bevair.com

an Ali Group Company



The Spirit of Excellence