



BEVERAGE-AIR

Project: _____	AIA#
Item: _____	
Location: _____	SIS#
Approved: _____	

WTRCS48HC CHEF BASE REFRIGERATOR

CHEF BASE REFRIGERATOR

MODEL:
WTRCS48HC

WTRCS48HC Two Drawer Chef Base
Hydrocarbon Series



3 Year Parts/Labor Warranty
Additional 4 Year Compressor Warranty

CABINET CONSTRUCTION

- Stainless steel front, sides, drawers and grille (galvanized back & bottom)
- Interior liner is made of corrosion resistant aluminum
- Top has full marine edge to prevent spills from dripping over sides
- Full electronic control
- Top weight capacity 1000 lbs
- One-piece, snap-in magnetic drawer gasket
- 12-Gauge stainless steel drawer slides with Delrin® rollers rated at 275 lbs
- Lifetime warranty on all drawers and slides
- Heavy duty, fire-proof, reinforced insulated 16 gauge top
- No heat shield required (must adhere to proper clearance per owners manual)
- Accommodates 6" deep full size food service pans (not included)
- Self-closing drawer feature
- Compressor available on left or right, specify at time of unit order
- 3" Casters, 2 with brakes standard

OPTIONS & ACCESSORIES

- Stainless steel back
- Stainless steel interior
- Additional pan supports
- 6" Adjustable legs, 6" seismic legs
- 6" Casters
- Gasket guards
- Flat top overhang
(up to 6" overhang on each side)
- Remote option*
(refrigerant must be specified at time of order, see note on back on page)

REFRIGERATION SYSTEM

- Uses environmentally friendly, energy efficient R290 refrigerant, and meets all regulatory requirements for CARB, SNAP, DOE & more
- Adaptive defrost
- Non-electric defrost with hot gas condensate evaporation
- Refrigerator capable of maintaining product temperature 36°F to 38°F



ENERGY STAR
Please verify qualifying units by visiting:
www.energystar.gov/cfs

3779 Champion Blvd., Winston-Salem, NC 27105
1-888-845-9800 Fax: 1-336-245-6453
Beverage-Air.com Sales@bevair.com



BEVERAGE-AIR

MODEL	WTRCS48HC
EXTERNAL DIMENSIONAL DATA	
Width Overall	48"
Depth Overall (with handle & bumper)	34 3/4"
Height Overall (with casters)	24 3/8"
Number of Drawers	2
Depth with Drawers Extended	57 3/4"
Drawer Opening (in)	27 3/8" x 6 1/2"
INTERNAL DIMENSIONAL DATA	
NET Capacity (cubic ft.)	8.59
Internal Width Overall (in)	34 7/8"
Internal Depth Overall (in)	26"
Internal Height Overall (in)	16 3/8"
ELECTRICAL DATA	
Full Load Amperes	1.70
REFRIGERATION DATA	
Horsepower	1/6
Capacity (BTU/Hr)*	1110
WEIGHT DATA	
Gross Weight	375 lbs
Height - Crated	27"
Width - Crated	58"
Depth - Crated	38"

*NOTE: Remote units are field wired and come with 6" legs.
Refrigerant must be specified at time of order.

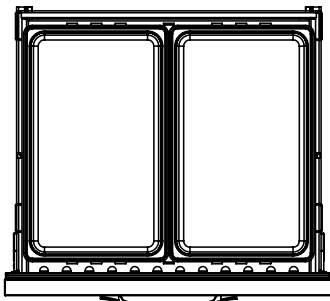

(Per drawer)

Chef Base Refrigerator Model: WTRCS48HC

Model Views

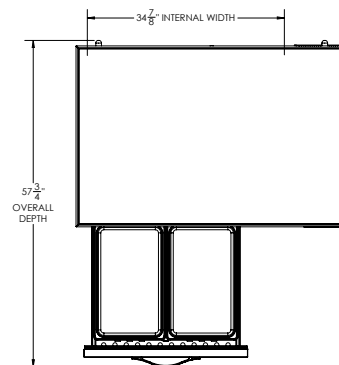

PLAN VIEW

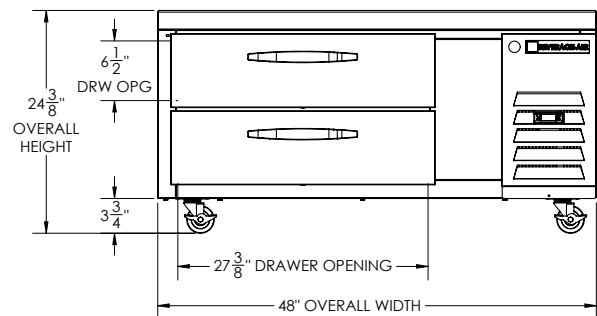

ELEVATION VIEW

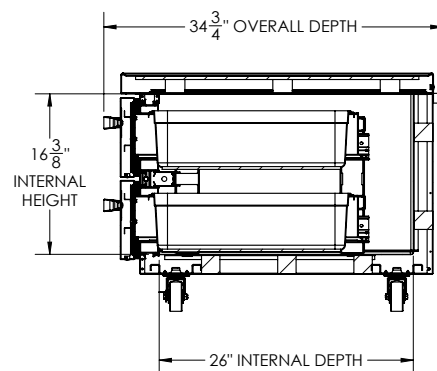

SIDE VIEW

*ELECTRICAL CONNECTION



115/60/1
NEMA 5-15P

Unit pre-wired at factory
and include 8' long cord
and plug set.



an Ali Group Company



The Spirit of Excellence