



BEVERAGE-AIR

Project: _____	AIA#
Item: _____	
Location: _____	SIS#
Approved: _____	

SPED60HC SANDWICH PREP: MEGA TOP SERIES

FOOD PREPARATION TABLES

**MODEL:
SPED60HC-18M-4**

**SPED60HC Sandwich Prep Table Mega Top
Hydrocarbon Series**



**3 Year Parts/Labor Warranty
Additional 4 Year Compressor Warranty**

CABINET CONSTRUCTION

- Stainless steel front, sides, top, drawer and grille (galvanized back & bottom)
- Interior liner is made of corrosion resistant aluminum
- Full electronic control
- Removable hoods made of matching stainless steel
- Airflow assures that product in open containers is kept below 41°F and above freezing
- Snap-In magnetic gaskets for positive drawer seal
- Painted aluminum drawer handles
- 6" Casters, 2 with brakes standard
- 10" Wide cutting board constructed of white polyethylene plastic
- Cutting board removable for cleaning
- Eighteen (18) 1/6 4" deep pans constructed of polycarbonate plastic
- Stainless steel drawer frames supported on telescoping drawer slides
- Drawer slides include locking mechanism that prevents drawers from being inadvertently pulled off cabinet
- Top and bottom drawers accommodate 6" deep pans

OPTIONS & ACCESSORIES

- Stainless steel back
- Stainless steel interior
- Overshelves (single or double)
- Crumb catcher
- Richlite cutting board
- Night cover
- Pan supports
- Pan support crossbar
- Pan configuration
- Locking Divider
- Digital / stem dial thermometer
- 6" legs or 3" casters
- Low profile casters
- Remote option* (see note on back page)

REFRIGERATION SYSTEM

- Uses environmentally friendly, energy efficient R290 refrigerant, and meets all regulatory requirements for CARB, SNAP, DOE & more
- Adaptive defrost
- Epoxy coated evaporator coil
- Enhanced airflow maintains temperatures between 36° - 38°F



Please verify qualifying units by visiting:
www.energystar.gov/cfs

3779 Champion Blvd., Winston-Salem, NC 27105
1-888-845-9800 Fax: 1-336-245-6453
Beverage-Air.com Sales@bevair.com



BEVERAGE-AIR

MODEL	SPED60HC-18M-4
EXTERNAL DIMENSIONAL DATA	
Width Overall	60"
Depth Overall	38 ³ / ₈ "
Height Overall with Casters	49"
Number Drawers	4
Depth with Drawer Open 90°	47 ³ / ₄ "
Drawer Opening	22 ⁵ / ₈ " x 11 ¹ / ₈ " 22 ⁵ / ₈ " x 7 ¹ / ₂ "
Width, Cutting Board	10"
INTERNAL DIMENSIONAL DATA	
NET Capacity (cubic ft.)	16.0
Internal Width Overall (in)	56"
Internal Depth Overall (in)	15 ³ / ₈ "
Internal Height (in)	23"
No. of Pans	18
ELECTRICAL DATA	
Full Load Amperes	5.4
REFRIGERATION DATA	
Horsepower	1/3
Capacity (BTU/Hr)	1549
SHIPPING DATA	
Gross Weight - Crated	481 lbs
Height - Crated	48"
Width - Crated	62"
Depth - Crated	39"

*NOTE: Remote units are field wired and come with 6" legs.
Refrigerant must be specified at time of order.

Food Preparation Table - Mega Top Model: SPED60HC-18M-4

Model Views

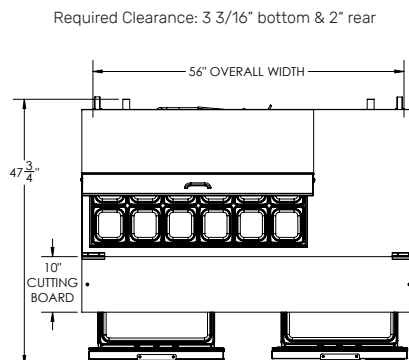

PLAN VIEW

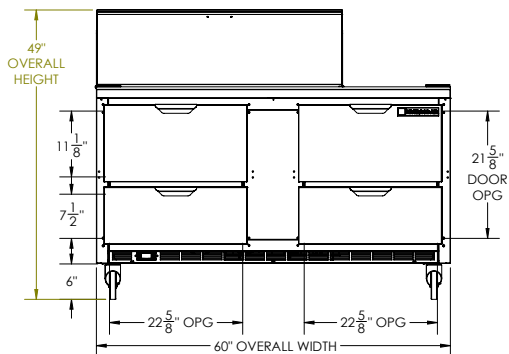

ELEVATION VIEW

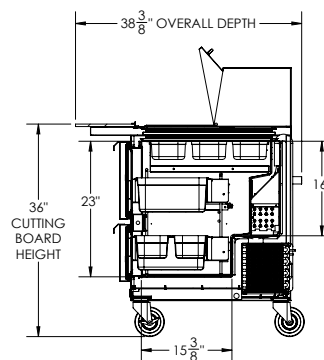

SIDE VIEW

*ELECTRICAL CONNECTION



115/60/1
NEMA 5-15P

Unit pre-wired at
factory and include 8'
long cord and plug set.



3779 Champion Blvd., Winston-Salem, NC 27105 1-888-845-9800 Fax: 1-336-245-6453 Beverage-Air.com Sales@beveair.com

an Ali Group Company



The Spirit of Excellence