



BEVERAGE-AIR

Project: _____	AIA#
Item: _____	
Location: _____	SIS#
Approved: _____	

FOOD PREPARATION TABLES

MODEL:
SPED36HC-08C-2

SPED36HC Sandwich Prep Table With 17" Cutting Board Hydrocarbon Series

SPED36HC SANDWICH PREP: CUT TOP SERIES



3 Year Parts/Labor Warranty
Additional 4 Year Compressor Warranty

CABINET CONSTRUCTION

- Stainless steel front, sides, top, drawers, and grille (galvanized steel back & bottom)
- Interior liner is made of corrosion resistant aluminum
- Removable hoods made of matching stainless steel
- Cut top
- Full electronic control
- Airflow assures that product in open containers is kept below 41°F and above freezing
- Eight (8) 1/6 4" deep pans constructed of polycarbonate plastic
- Snap-In magnetic gaskets for positive drawer seal
- Painted aluminum drawer handles
- 17" Wide cutting board constructed of white polyethylene plastic
- Cutting board removable for cleaning
- Pans furnished are 4" deep constructed of polycarbonate plastic
- Stainless steel drawer frames supported on telescoping drawer slides
- Drawer slides include locking mechanism that prevents drawers from being inadvertently pulled off cabinet
- 6" Casters, with (2) brakes standard

OPTIONS & ACCESSORIES

- Stainless steel back
- Stainless steel interior
- Overshelves (single or double)
- Crumb catcher kit
- Richlite cutting board
- Night cover
- Bottle organizer
- Pan supports
- Pan support crossbar
- Pan configuration
- 6" legs or 3" casters
- Low profile casters
- Remote option* (see note on back page)

REFRIGERATION SYSTEM

- Uses environmentally friendly, energy efficient R290 refrigerant, and meets all regulatory requirements for CARB, SNAP, DOE & more
- Adaptive defrost
- Epoxy coated evaporator coil
- Enhanced airflow maintains temperatures between 36° - 38°F



Please verify qualifying units by visiting:
www.energystar.gov/cfs

3779 Champion Blvd., Winston-Salem, NC 27105
1-888-845-9800 Fax: 1-336-245-6453
Beverage-Air.com Sales@bevair.com



BEVERAGE-AIR

MODEL	SPED36HC-08C-2
EXTERNAL DIMENSIONAL DATA	
Width Overall	36"
Depth Overall	38 ¼"
Height Overall with Casters	45"
Number Drawers	2
Depth with Drawer Open 90°	48 ½"
Drawer Opening	31 ⅝" x 11 ⅛" 31 ⅝" x 7 ½"
Width, Cutting Board	17"
INTERNAL DIMENSIONAL DATA	
NET Capacity (cubic ft.)	10.01
Internal Width Overall (in)	32"
Internal Depth Overall (in)	15 ⅜"
Internal Height Usable (in)	23"
No. of Pans	8
ELECTRICAL DATA	
Full Load Amperes	2.0
REFRIGERATION DATA	
Horsepower	1/6
Capacity (BTU/Hr)	1140
SHIPPING DATA	
Gross Weight - Crated	276 lbs
Height - Crated	44"
Width - Crated	51"
Depth - Crated	33"

*NOTE: Remote units are field wired and come with 6" legs.
Refrigerant must be specified at time of order.

Food Preparation Table - Cut Top Model: SPED36HC-08C-2

Model Views

Required Clearance: 3 3/16" bottom & 2" rear

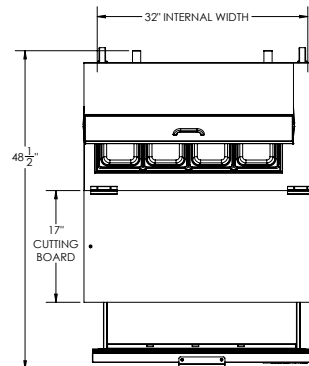

PLAN VIEW

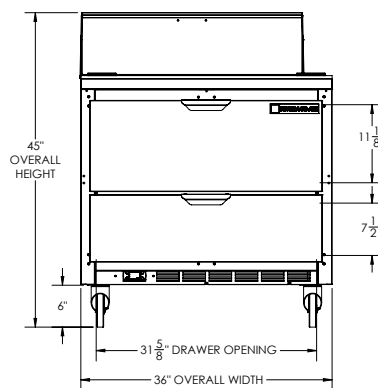

ELEVATION VIEW

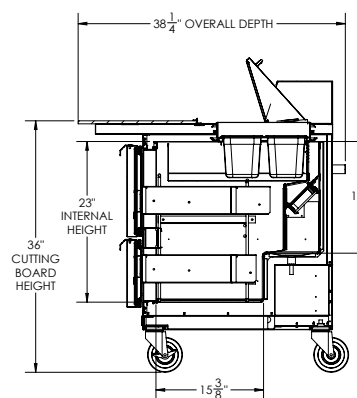

SIDE VIEW

*ELECTRICAL CONNECTION



115/60/1
NEMA 5-15P

Unit pre-wired at
factory and include 8'
long cord and plug set.



3779 Champion Blvd., Winston-Salem, NC 27105 1-888-845-9800 Fax: 1-336-245-6453 Beverage-Air.com Sales@bevair.com

an Ali Group Company



The Spirit of Excellence