



BEVERAGE-AIR®

Project: _____	AIA#
Item: _____	
Location: _____	SIS#
Approved: _____	

SMF34HC SINGLE ACCESS, FORCED AIR: SCHOOL MILK SERIES

SCHOOL MILK FORCED AIR COOLER

SMF34HC Single Access Cooler
Hydrocarbon Series

MODEL:
SMF34HC-1-S



3 Year Parts/Labor Warranty
Additional 4 Year Compressor Warranty

CABINET CONSTRUCTION

- Stainless steel exterior and interior
- Stainless steel lids, hinges doors and door latches
- Full electronic control
- Heavy-duty epoxy coated steel wire floor racks standard
- Floor drain is centrally located for easy cleaning, connecting to drain hose with hose adapter
- Flexible compression door gaskets ensure tight seal
- Self-latching doors/lids with safety bumpers
- Exterior thermometer
- Cylinder lock
- 6" Heavy-duty plate casters (2 with locks)
- Balanced, forced-air refrigeration system provides rapid chilling of product

OPTIONS & ACCESSORIES

- Corner bumpers
- Cafeteria tray slide
- Graphics

REFRIGERATION SYSTEM

- Uses environmentally friendly, energy efficient R290 refrigerant, and meets all regulatory requirements for CARB, SNAP, DOE & more
- Maintains continuous milk temperature between 36° - 40°F



Please verify qualifying units by visiting:
www.energystar.gov/cfs

3779 Champion Blvd., Winston-Salem, NC 27105
1-888-845-9800 Fax: 1-336-245-6453
Beverage-Air.com Sales@bevair.com



BEVERAGE-AIR

School Milk Cooler - Forced Air Cooler Model: SMF34HC-1-S

MODEL	SMF34HC-1-S
EXTERNAL DIMENSIONAL DATA	
Width Overall	34"
Depth Overall	33 5/8"
Height Overall with Casters	46 7/8"
Number of Lids/Doors	Single Access
Depth with Door Open 90°	48 1/2"
INTERNAL DIMENSIONAL DATA	
NET Capacity (cubic ft.)	13.59
Internal Width Overall (in)	31"
Internal Depth Overall (in)	30"
Internal Height Usable (in)	24 7/8"
CASE CAPACITY	
13" X 13" X 11"	8
19" X 13" X 11"	4
ELECTRICAL DATA	
Full Load Amperes	3.0
REFRIGERATION DATA	
Horsepower	1/4
Capacity (BTU/Hr)	1010
SHIPPING DATA	
Gross Weight - Crated	335 lbs
Height - Crated	54"
Width - Crated	39"
Depth - Crated	38"

Model Views

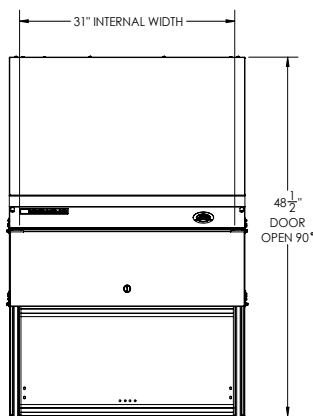

PLAN VIEW

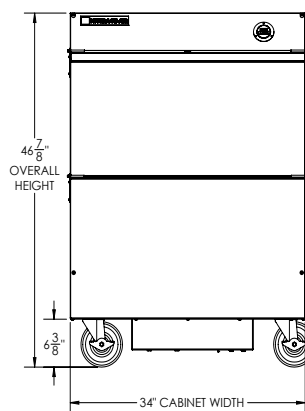

ELEVATION VIEW

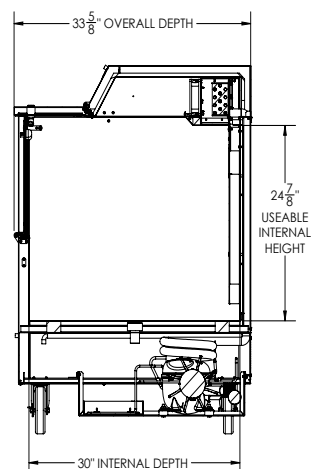

SIDE VIEW

ELECTRICAL CONNECTION



115/60/1
NEMA 5-15P

Units pre-wired at factory and include 8' long cord and plug set.



3779 Champion Blvd., Winston-Salem, NC 27105 1-888-845-9800 Fax: 1-336-245-6453 Beverage-Air.com Sales@bevoir.com

an Ali Group Company



The Spirit of Excellence