



BEVERAGE-AIR

Project: _____

AIA#

Item: _____

Location: _____

SIS#

Approved: _____

BB BAR EQUIPMENT- BACK BAR REFRIGERATOR

BB48HC Glass Door Food Rated & Pass-Thru /SS Top
Hydrocarbon Series

MODELS:
BB48HC-1-FG-PT-B-27
BB48HC-1-FG-PT-S-27

3 Year Parts/Labor Warranty

Additional 4 Year Compressor Warranty

CABINET CONSTRUCTION



BB48HC-1-FG-B-PT-27

- Exterior black or stainless steel
- Stainless steel interior
- Full electronic control
- Stainless steel top
- Two (2) epoxy coated shelves per section, standard
- Self-closing doors
- Stay-open feature & lock standard
- Magnetic door gaskets provide positive door sealing
- LED lighting
- Certified for open food product
- Balanced, forced air refrigeration system provides rapid chilling of product
- Maintains product temperature between 36°F and 38°F

OPTIONS & ACCESSORIES

- Wine model (40°-60° models)
- Wine shelf divider
- Sliding glass doors
- Underbar models available
- Additional shelves
- Additional shelf clips
- 3" or 6" casters
- 6" Black legs
- Remote option
(Refrigerant must be specified at time of order, see note on back on page)

REFRIGERATION SYSTEM

- Refrigeration system uses R290 refrigerant to comply with all environmental concerns
- Automatic, non-electric defrost
- Epoxy coated evaporator coil

BB48HC Back Bar Refrigerators: Food Rated Pass-Thru Model



3779 Champion Blvd., Winston-Salem, NC 27105
1-888-845-9800 Fax: 1-336-245-6453
Beverage-Air.com sales@bevair.com



BEVERAGE-AIR

Bar Equipment—Glass Door Food Rated & Pass-Thru

Models: BB48HC-1-FG-PT-B-27, BB48HC-1-FG-PT-S-27

MODEL	BB48HC-1-FG-PT-B-27	BB48HC-1-FG-PT-S-27
EXTERNAL DIMENSIONAL DATA		
Width Overall	48"	48"
Depth Overall with Han-	27 3/8"	27 3/8"
Height Overall	36"	36"
Number of Doors	4	4
Depth with Door Open 90°	60 7/8"	60 7/8"
Door Opening (in)	16 1/2" x 29 1/4"	16 1/2" x 29 1/4"
INTERNAL DIMENSIONAL DATA		
NET Capacity (cubic ft.)	13.6	13.6
Internal Width Overall (in)	36 1/8"	36 1/8"
Internal Depth Overall (in)	19 3/8"	19 3/8"
Internal Height Overall (in)	28"	28"
Number of Shelves	4	4
Number of Kegs	2	2
ELECTRICAL DATA		
Full Load Amps* 115/60/1	3.1	3.1
REFRIGERATION DATA		
Horsepower*	1/3	1/3
Capacity (BTU/Hr)*	1942	1942
WEIGHT DATA		
Gross Weight (Crated lbs)	320 lbs	336 lbs
Height - Crated	38"	44"
Width - Crated	51"	51"
Depth - Crated	26 1/2"	27"

*NOTE: Remote units are field wired and comes with 6" legs. Refrigerant must be specified at time of order.

Model Views

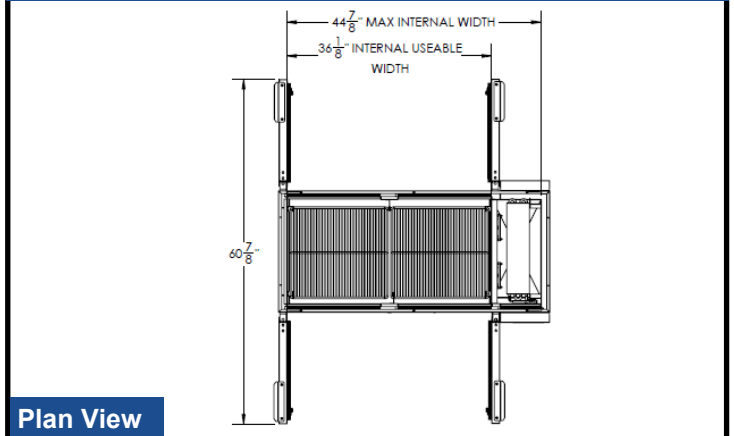

Plan View

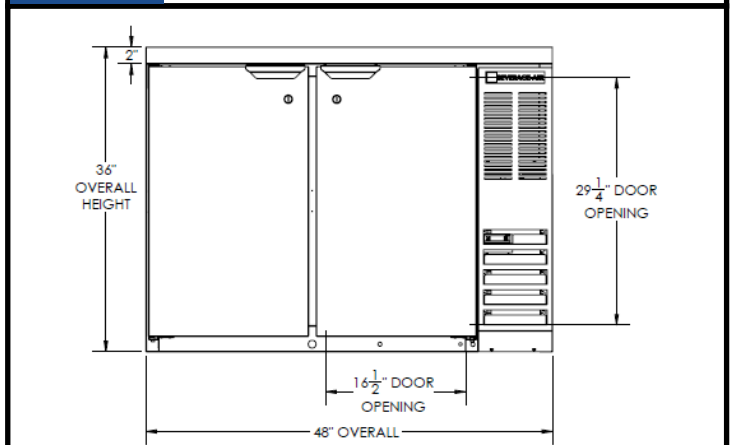

Elevation View

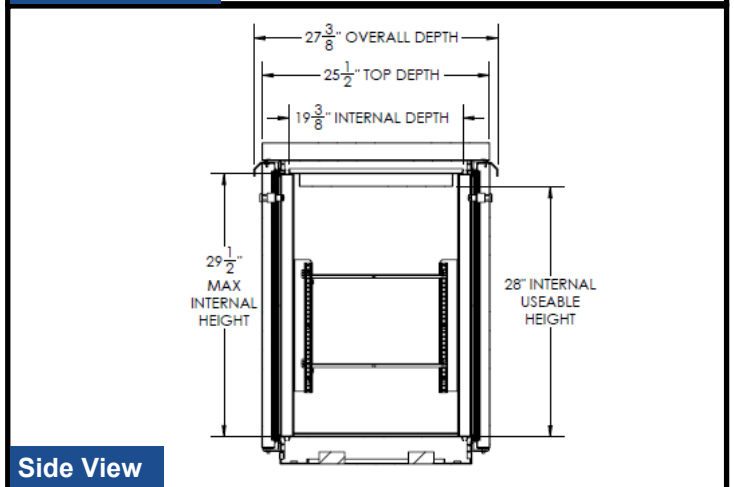

Side View

ELECTRICAL CONNECTION



115/60/1
NEMA-5-15P

Units pre-wired at factory and include 8' long cord and plug set.



an Ali Group Company



The Spirit of Excellence

3779 Champion Blvd., Winston-Salem, NC 27105
1-888-845-9800 Fax: 1-336-245-6453
Beverage-Air.com sales@bevair.com