



Three Compartment Economy Sink

Stainless Steel Compartment Sinks



Use your smart phone to scan the above QR code to visit our website:
www.bk-resources.com

Certifications:



Features:

- 1/4" Pitched Drainboards To Ensure Proper Drainage
- 1 1/2" Rounded Front and Side Edges
- Accommodates 8" On Center Faucets
- Drains Included
- 9" Backsplash
- 6 Month Warranty



ES-3-24-14-24T

Material:

- 18 ga. Stainless Steel
- 1 5/8" Galvanized Legs
- Adjustable High Impact Corrosion Resistant Feet

Options:

- Pre-Rinse Units & Faucets
- Lever Drains
- Upgraded Bullet Feet
- Slant Rack Shelf (BK-SSH)
- End Splash (BKS-RES)
- S/S Basket Drain (BKDR-4-304)

Part Number	Unit Size (l x w)	Bowl Dim. (l x w x d)	Sets of Faucet Holes	Drainboard Size	Product Weight (lbs)
ES-3-1014-10	35 1/2" x 19 13/16"	10" x 14" x 10"	1	NO DRAINBOARD	42.00
ES-3-1014-10-12T	54" x 19 13/16"	10" x 14" x 10"	1	(2) - 12"	48.00
ES-3-1014--10-15T	60" x 19 13/16"	10" x 14" x 10"	1	(2) - 15"	51.00
ES-3-1220-12-12T	60" x 25 13/16"	12" x 20" x 12"	1	(2) - 12"	-
ES-3-1416-12-12T	66" x 21 13/16"	14" x 16" x 12"	1	(2) - 12"	-
ES-3-18-12-18T	90" x 23 13/16"	18" x 18" x 12"	1	(2) - 18"	79.00
ES-3-1620-12-18T	84" x 25 13/16"	16" x 20" x 12"	1	(2) - 18"	-
ES-3-24-14-24T	120" x 29 13/16"	24" x 24" x 14"	2	(2) - 24"	126.00

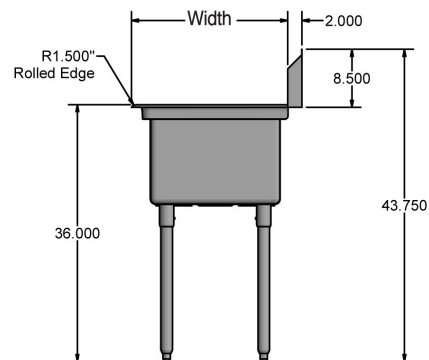
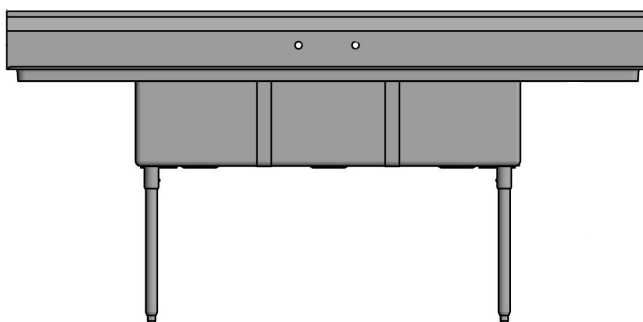
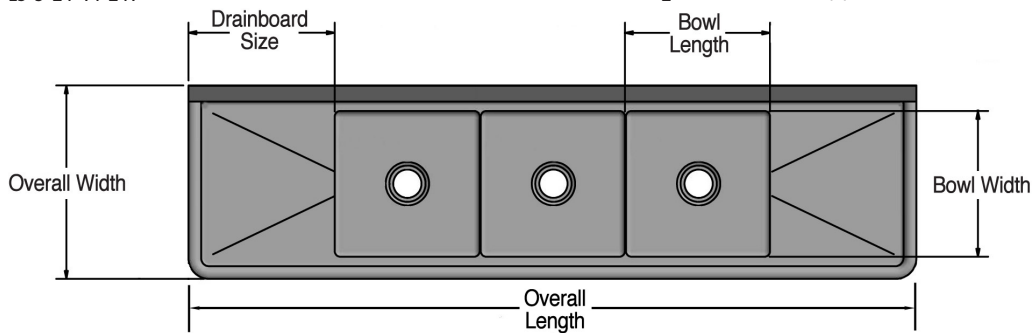

PRODUCT DATA SHEET

BK RESOURCES

