



One Compartment Economy Sink

Stainless Steel Compartment Sinks



Use your smart phone to scan the above QR code to visit our website:
www.bk-resources.com

Certifications:



Features:

- 1/4" Pitched Drainboards To Ensure Proper Drainage
- 1 1/2" Rounded Front and Side Edges
- Accommodates 8" On Center Faucet
- Drain Included
- 9" Backsplash
- 6 Month Warranty

Material:

- 18 ga. Stainless Steel
- 1 5/8" Galvanized Legs
- Adjustable High Impact Corrosion Resistant Feet

Options:

- Pre-Rinse Units & Faucets
- Lever Drains
- Upgraded Bullet Feet
- Slant Rack Shelf (BK-SSH)
- End Splash (BKS-RES)
- S/S Basket Drain (BKDR-4-304)

Part Number	Unit Size (l x w)	Bowl Dim. (l x w x d)	Drainboard	Product Weight (lbs)
ES-1-18-12-18L	38 1/2" x 23 ^{13/16"}	18" x 18" x 12"	(1) Left - 18"	37.00
ES-1-18-12-18R	38 1/2" x 23 ^{13/16"}	18" x 18" x 12"	(1) Right - 18"	37.00

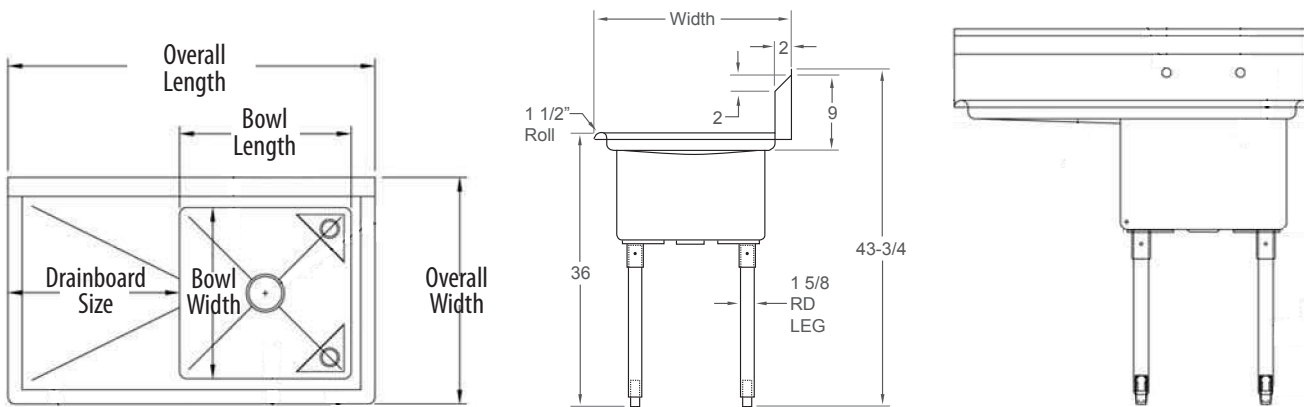

PRODUCT DATA SHEET

RESOURCES

