



# 5" Riser Tables

## Stainless Steel Riser Tables



Use your smart phone to scan the above QR code to visit our website:  
[www.bk-resources.com](http://www.bk-resources.com)



### Certifications:



### Features:

- Two (2) Sound Deadened Integrally Welded 5" "C" Channels to Reinforce and Maintain Level Working Surface
- Legs 1 5/8" Diameter
- 5" Riser
- 84" & 96" Have 6 Legs

### Options:

- Single & Double Overshelves
- Drawer Assemblies
- Casters
- Upgraded Bullet Feet
- Extra Shelves
- Adjustable Table Mount Pot Rack

### Material:

#### QVTR5 Series: S/S w/ Stainless Steel Legs & Undershelf

- T-304 14 ga. Stainless Steel Top
- Stainless Steel Legs & Adjustable Undershelf
- 1 1/4" Adjustable Stainless Steel Feet

Part #	Length	Width	Product Weight (lbs)
QVTR5-8424	84"	24"	-
QVTR5-3630	36"	30"	66.00
QVTR5-4830	48"	30"	88.00
QVTR5-6030	60"	30"	105.00
QVTR5-7230	72"	30"	122.00
QVTR5-8430	84"	30"	146.00
QVTR5-9630	96"	30"	162.00

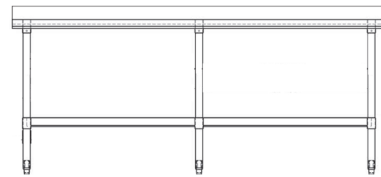
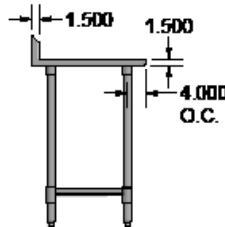
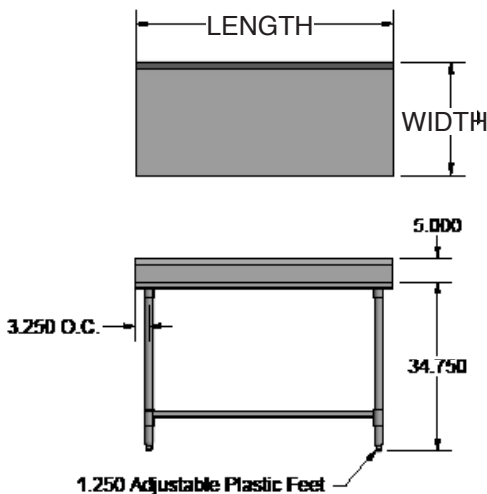

TABLES 7 FT. AND LARGER ARE FURNISHED WITH SIX (6) LEGS

PRODUCT DATA SHEET

RESOURCES

