



Open Base Riser Top Work Table

Stainless Steel Work Tables



Use your smart phone to scan the above QR code to visit our website:
www.bk-resources.com

Certifications:



Features:

- 1 5/8" Legs
- 5" Riser
- Legs Adjust 1" in Height
- Ships KD
- Two Sound Deadened Integrally Welded 5" C Channels to Reinforce & Maintain Level Working Surface
- 85" & 96" Tables Have 6 Legs

Options:

- Single & Double Overshelves
- Drawer Assemblies
- Casters
- Adjustable Table Mount Pot Rack



Material:

CTTR50B Series: S/S w/ Galvanized Legs

- T-304 16 ga. Stainless Steel Top
- Galvanized Legs & Bracing
- Adjustable High Impact Corrosion Resistant Feet
- Capacity: 800 lbs Evenly Distributed

CVTR50B Series: Stainless Steel w/ Stainless Steel Legs

- T-304 16 ga. Stainless Steel Top
- Stainless Steel Legs & Bracing
- Adjustable Stainless Steel Feet
- Capacity: 1,200 lbs Evenly Distributed

CTTR50B Series

S/S w/ Galv. Legs

Length	T-304 S/S 30" Width	Product Weight (lbs)
36"	CTTR50B-3630	68.00
48"	CTTR50B-4830	84.00
60"	CTTR50B-6030	100.00
72"	CTTR50B-7230	109.00
84"	-	-
96"	CTTR50B-9630	146.00

CVTR50B Series

S/S w/S/S Legs

T-304 S/S 30" Width	Product Weight (lbs)	T-304 S/S 24" Width	Product Weight (lbs)
CVTR50B-3630	66.00	-	-
CVTR50B-4830	88.00	-	-
CVTR50B-6030	105.00	-	-
CVTR50B-7230	122.00	-	-
CVTR50B-8430	CVTR50B-8424		-
CVTR50B-9630	162.00	-	-

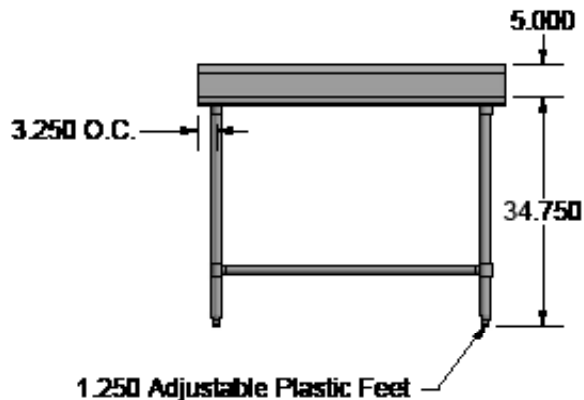
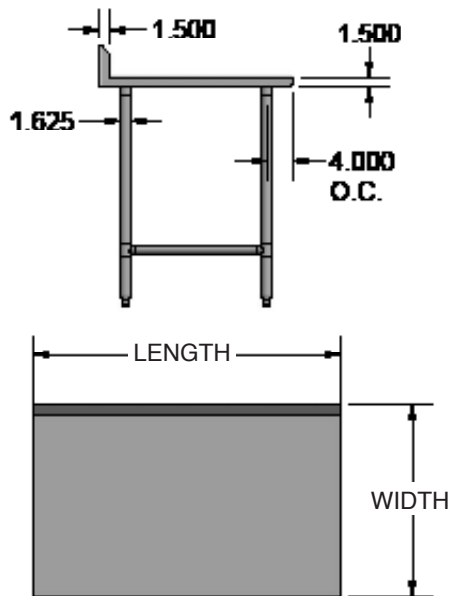

PRODUCT DATA SHEET

BK RESOURCES

